

APPROVED
PRIMARY ELECTRICAL
INSTALLATION



Contractor Training Class
2024

Class Timeline and Housekeeping

- Four hour class with a 10 minute break every 50 minutes
 - Coffee
 - Bathrooms
 - Exits
 - AEDs
 - Sign-in

Introductions

- ⦿ Brian Roden, T&D Manager
- ⦿ Carly Beck, Standards Engineer
- ⦿ Jolynn Burk – Primary Contractor Coordinator

- ⦿ Construction Superintendents

- ⦿ New Construction
 - Justin Rindt, New Construction Designer
 - Sean Boyle, Construction Inspector
 - Zach Muonio, Construction Inspector
 - Jim Angel, Construction Inspector

- ⦿ Construction Coordinators

- ⦿ Justin Zucconi, Safety Manager

Program Background

Began in 1994 to prevent a rate increase and has grown into what it is today

- ⦿ PUD received approval from State L&I
 - Which requires this training
 - And they require the signed agreement
- ⦿ Benefits
 - Competitive pricing/free market
 - Reduces pricing
 - Covers the cost of the installation
- ⦿ Safe quality installations
- ⦿ Benefits our customers

Delisting of Contractor

- ⦿ Program violations:
 - Violation of safety practices and standards
 - L&I will be notified
 - A specific job fails two inspections
 - Contractor fails to correct unsatisfactory installations within 10 working days
 - Non-compliance with the Electrical System Installation Agreement

Online Information

- All information covered today is available on the CPU website:

www.clarkpublicutilities.com

- QR Codes on business cards – links to Commercial and Residential Electric Service Handbooks
 - Use as guide; local, state and federal codes supersedes
 - CPU standards – not construction procedures (look at material directions for procedures)
- Please exhaust these resources before calling with questions

Process of the Job



- **Call your CPU Designer at least 2 weeks before starting!!!!**
- After primary trench and conduit is installed, call CPU Ops for a primary inspection at least two days ahead of schedule

360-992-8839

Process of the Job



- Approved Contractors CANNOT work with or in energized equipment
 - CPU journeyman will unlock equipment and provide a safety watch. No physical help should be assumed or expected.
- CPU journeyman has the right to STOP the standby if OSHA violations are observed! (Trenching/shoring, PPEs, etc.)

360-992-8839

Safety

- ⦿ Dangerous environments
- ⦿ Consistency
- ⦿ Safety violations reported to L&I
- ⦿ Standards
- ⦿ Trenching & Excavation

Safety

- ⦿ Common Violations seen by our Inspectors
 - Dig-in
 - Cutting & windowing conduits
 - Closer than 10' to OH primary
 - Always assume cable is energized
 - If questions, call us before proceeding

Arc Flash

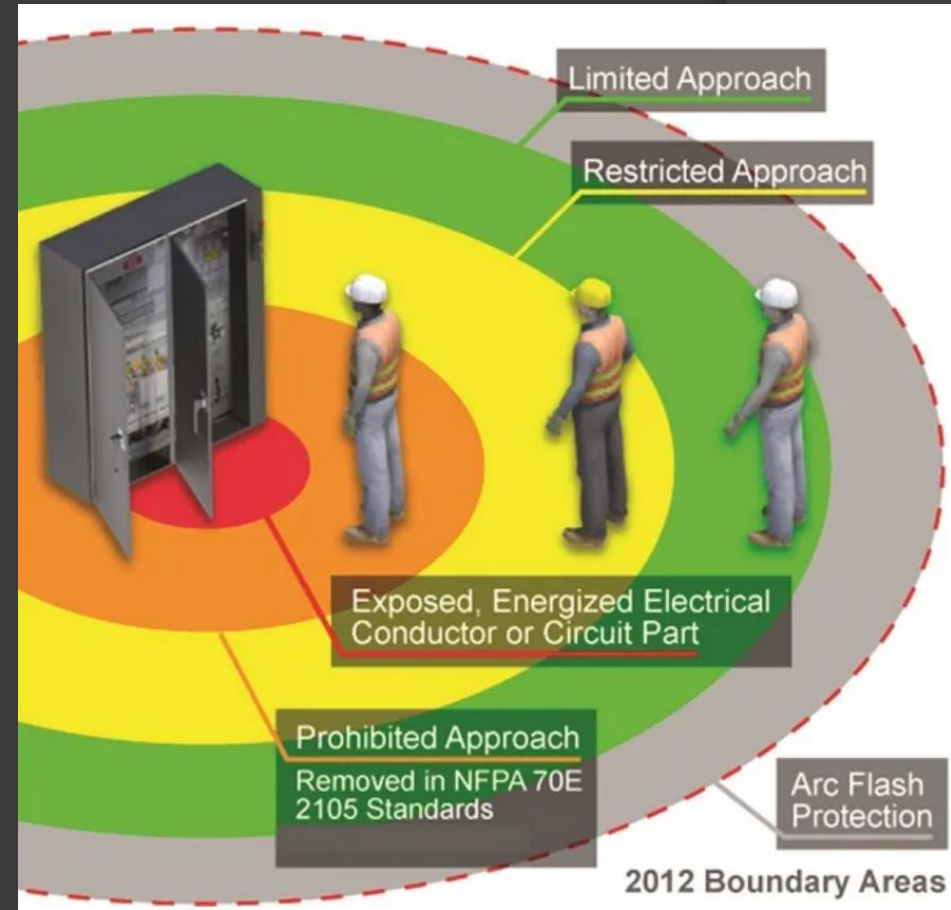
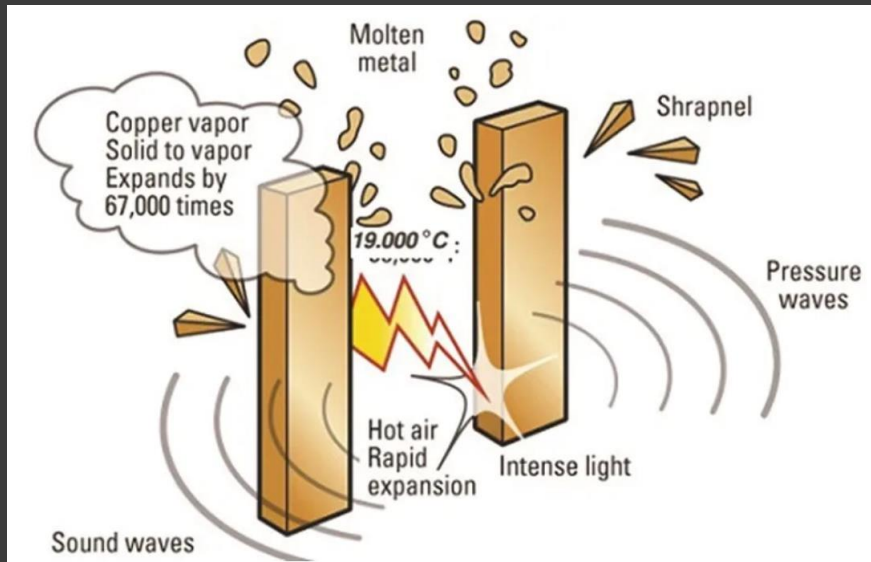

- Workers exposure during arc flash
- Identify approach zones on worksite for all workers.

Arc Flash



Changes/Updates

- Primary Contractor: You are responsible for your sub-contractors.
- Secondary Inspections (new) call Construction Services at 360-992-8558

Right of Way Work Permits

- Clark County and WSDOT require a pre-construction meeting in the field
- Notify both agencies 24 hours prior to start of work
- Adhere to erosion control requirements
- Have an approved traffic control plan
- Plan for timely and proper restoration
- If CPU pulled the permit (Clark County, WSDOT) these agencies will notify us with problems and we will let you know
- The customer secures ROW permits within any city limits
- Repeat ROW problems will lead to delisting

Comments from the County

- Utility permit (**PWU**) is required when working within Clark County Public ROW.
- Contractor working on behalf of utility **must** have copy of PWU permit at all times.
- Traffic Impacts: 1 Lane impacts per WSDOT TC-1 is approved. Any other TCP's will need approval from Clark County Transportation
@trafficpermitrequests@clark.wa.gov

Comments from the County

- ◎ Text or E-mail Notification required **24-hrs prior.** Please reference **PWU #.**

Contact Information:

- ◎ Eddie Barnhart (Inspection) – 360-356-0578 or eddie.barnhart@clark.wa.gov
- ◎ Nikki Olsen (Permitting) – 360-619-8536 or nicole.olsen@clark.wa.gov
- ◎ **No notification may result in shutting down work until next day.**

Comments from the County

- Erosion:
- Site Stabilization required:

(2) days October 1 – April 30;

(7) days May 1 – September 30

- The utility shall make adequate provisions for erosion and sediment control. Requirements for such erosion and sedimentation control will be determined on a case-by-case basis.

Land Use Documents

- ⦿ Easements – must be signed prior to starting
- ⦿ ROWs – must have permit in hand prior to starting
- ⦿ PUEs
- ⦿ These are recorded agreements that give a utility the legal right to use and access a specific area of property
- ⦿ Property is still owned by customer
- ⦿ Must be installed to design

Material Handling

Material Handling

⦿ Important notes on cable reel storage:

- Seal end of cable to prevent entry of moisture
- Leave factory protective cover on as long as possible, preferably cover if outside for long periods
- Never store reels on side

If the CPU test shows the cable is bad, the contractor will replace it at the **contractor's expense.**



Material Handling



● Installation/pulling:

- Sufficient approved cable lubricant shall be used at the start and during the pull (Polywater J)
- Bends shall be clean and smooth
- The total angles shall not exceed 270° unless approved by a CPU engineer
- Cable attachments shall either be basket/sock or pulling eye
- Never allow tension at the reels during the pull.
 - Cable should be slack going into the conduit
- Keep transformers on level ground

Trenching and Conduit

Trenching and Conduit



- ⦿ Before you dig, call 811 and know the site location
- ⦿ Trenching needs to be done by an approved contractor within all ROW's and PUE's
 - Most cases require a 42" deep trench
 - We want them 1'-3' off of the driveways unless otherwise specified
 - The driveways need to be in place
 - We require a smooth trench bottom, two feet wide
 - We do not allow the use of trenchers or plows

Trenching and Conduit

- Standard for joint trench from the E-Guide:
 - Power towards the road
 - Phone towards the field
 - Gas towards the field and one foot of separation
 - Wet utilities minimum 5-foot separation

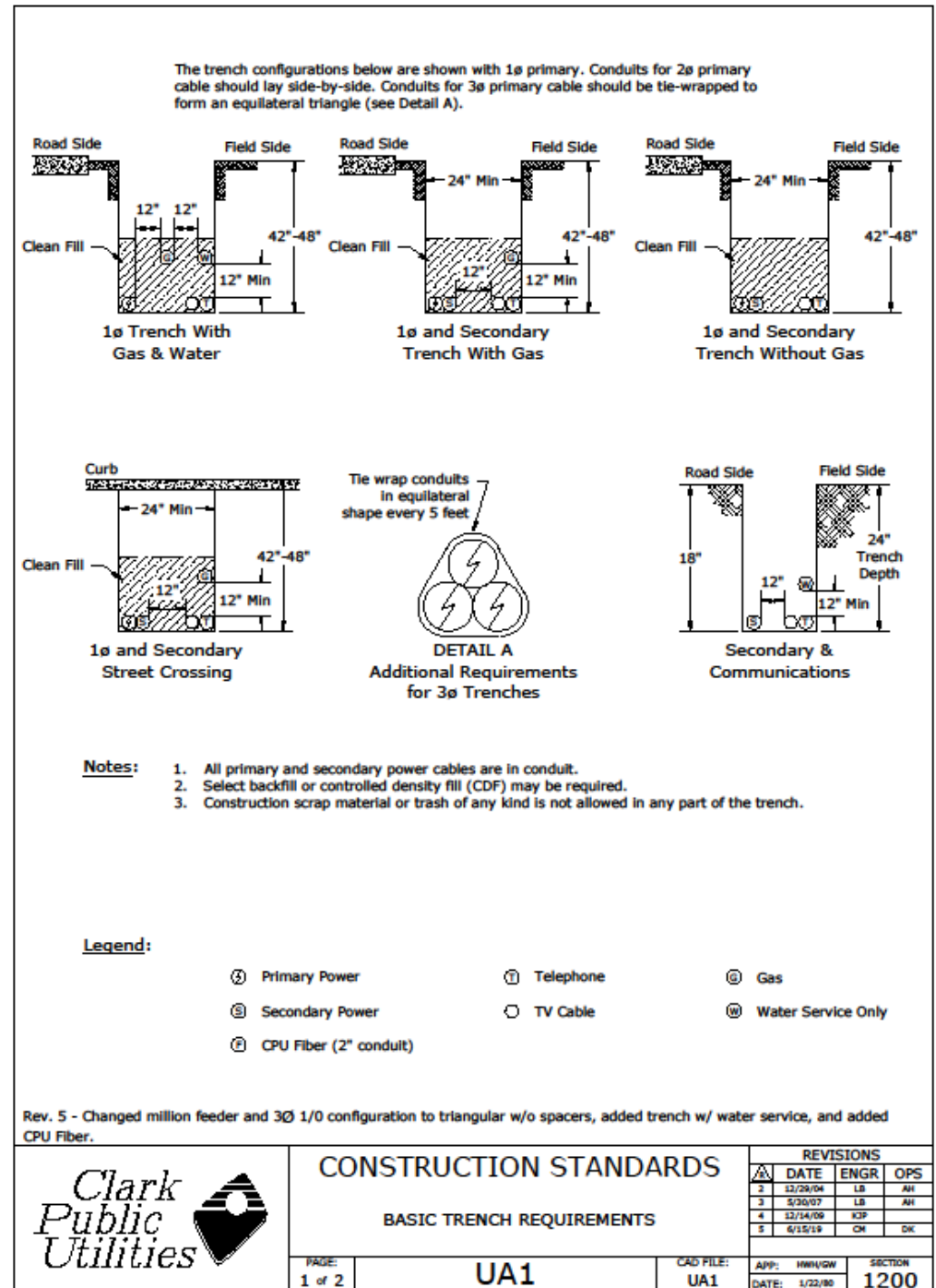

Trenching and Conduit



- Conduit Installation-All power cables will be installed in conduit
- Beware installations prior to 2005 were commonly direct buried, not in conduit

Trenching and Conduit



- You are liable for your trenches: barricade or ribbon off

Trenching and Conduit



- You are liable for your trenches: barricade or ribbon off

Trenching and Conduit

- All primary and secondary cables shall be in conduit
- All risers above finished grade shall be in **Schedule 80** PVC
- Acceptable conduit sizes are as follows unless otherwise specified
 - 1Ø, 1/0 primary cable in (1) 2" conduit
 - 3Ø, 1/0 primary cable in (1) 4" or (3) 2" conduits
 - Triplex secondary cable in (1) 3" conduit
 - 3Ø, 1000MCM cable in (3) 4" conduits
- All conduit terminations shall have end bells or collars
- All conduit installed for future use shall be marked and tagged

Trenching and Conduit

- Unused conduits shall have removable plugs designed for that purpose in both ends (need tags)
- All street and road crossings shall be at property lines
- Conduit sweeps shall be 24" secondary and 36" primary radius
- Conduits shall be installed so that cable is pulled toward the end bells to avoid scraping cable on sharp edges of conduit
- All cut ends of conduit shall be square
- Steel mandrels shall be pulled through the conduits to detect damage and debris

Trenching and Conduit



- ◎ Cross Country Secondary
 - 24" of cover

Trenching and Conduit



- ◎ Joint Trench: **Fail**
 - Looks like spaghetti!

Trenching and Conduit



PASS

◎ Joint Trench: Pass

- Straight and free of debris - Streetlight, Primary, Secondary

Trenching and Conduit



◎ Another passing trench

Trenching and Conduit



- ◎ Road Crossing

- Leave ends of pipe exposed for inspection

Trenching and Conduit

- Conduit installation shall be 2", 4" or 6" gray polyethylene pipe, SDR ≥ 13.5
- All connections to bore pipe will be made by mechanical coupling (Raceways Technologies #S80-2PE-PVC and Raceway Technologies #S80-4PE-PVC)



Trenching and Conduit

- A bore log shall be provided to CPU via email at time of trench/conduit inspection request
- The depth of the conduit shall be identified by a stake with the depth every 10 feet along the route in unpaved areas and by the depth written in marker paint every 10 feet along the route in paved areas
- The conduit depth shall conform to the CPU standards of 42" nominal depth
- All installed conduits shall be "proofed" using the appropriate mandrel, and have a 2500 pound, $\frac{3}{4}$ " sequentially-numbered, continuous "mule tape" installed
- CPU reserves the option to require "potholing" to determine depth and location for any installations that are questionable
- Required "potholing" will be at the contractor's expense

Setting Single-Phase Transformers (conduit trees)

Single-Phase Transformers



- Tree up conduit with Makeup Board
- Make sure they are exactly where the print stakes them
- If there is a concern over placement of any equipment, contact the designer to address BEFORE continuing with the install

Single-Phase Transformers

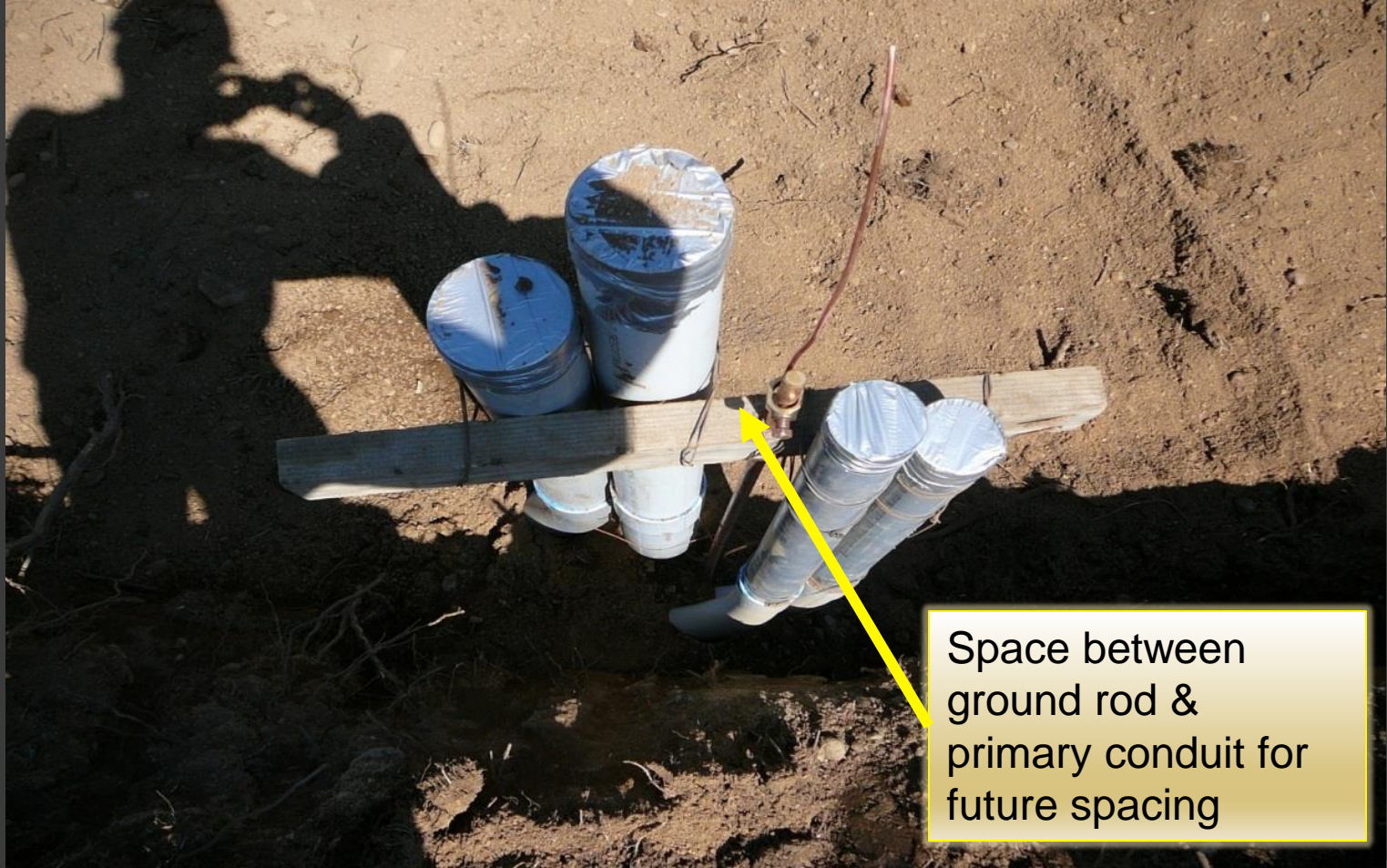

Space between
ground rod &
primary conduit for
future spacing

Single-Phase Transformers



- Evenly distribute backfill around tree to support installation and not push pipe over
- Cover ends of pipe to keep debris from entering conduit

Single-Phase Transformers



- ◎ Square the trees with the direction the transformer should face
- ◎ Compact fill evenly around the conduits

Single-Phase Transformers



- 5/8" Minus Rock fill - minimum 1-1/2 yards
- Soil conditions may require additional fill

Single-Phase Transformers



- Remove Makeup Board and compact properly
- Cut conduit and drive ground rod flush

Single-Phase Transformers

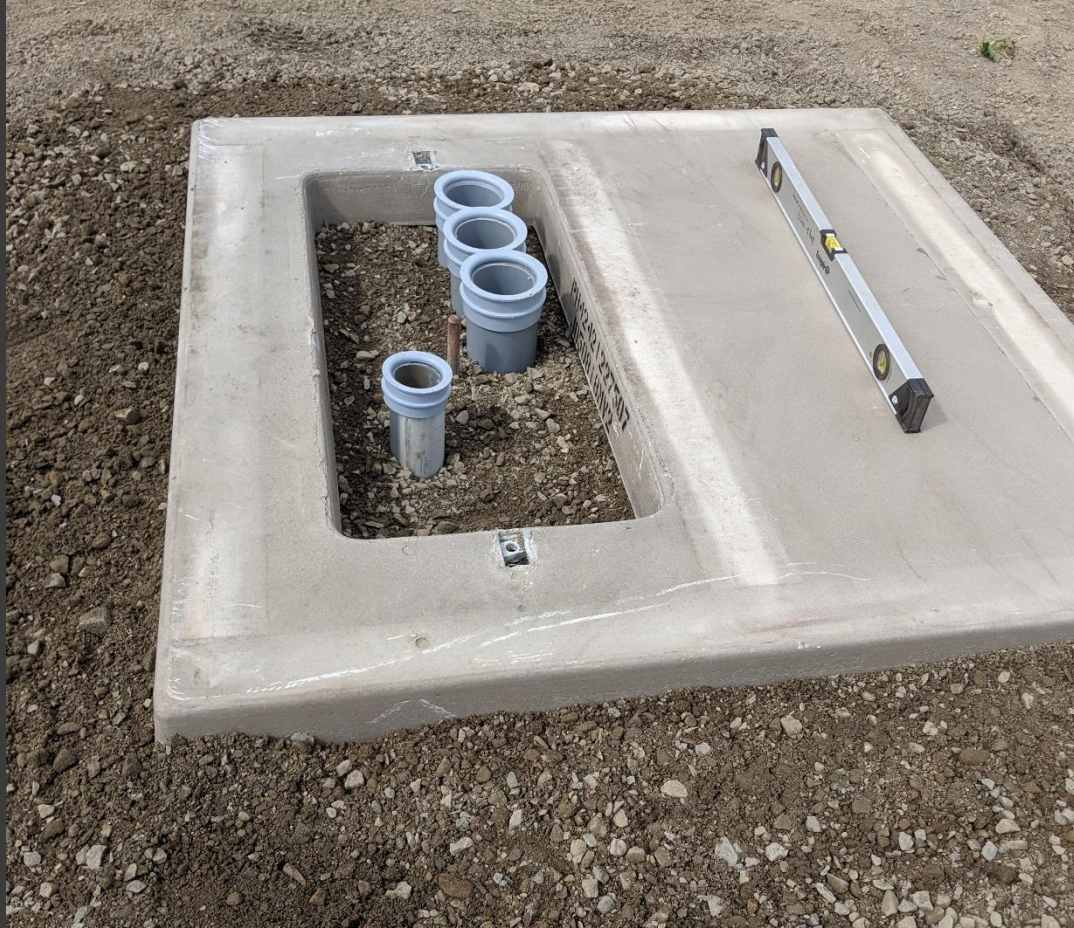

- Set
- Orientate
- Level pad

Single-Phase Transformers

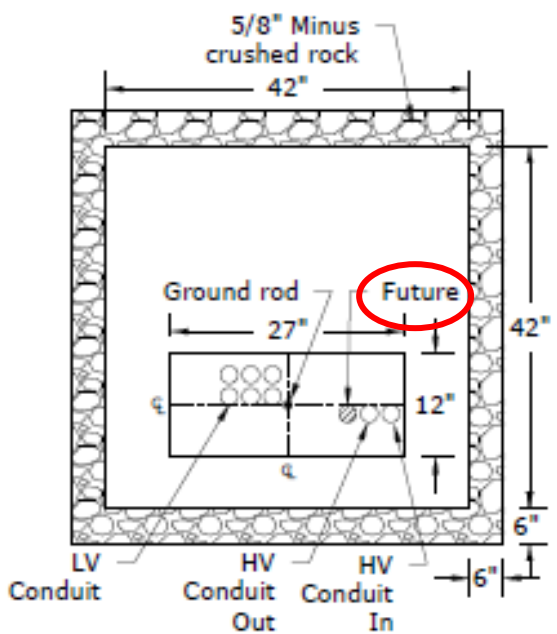

25-75 KVA PAD
PLAN VIEW

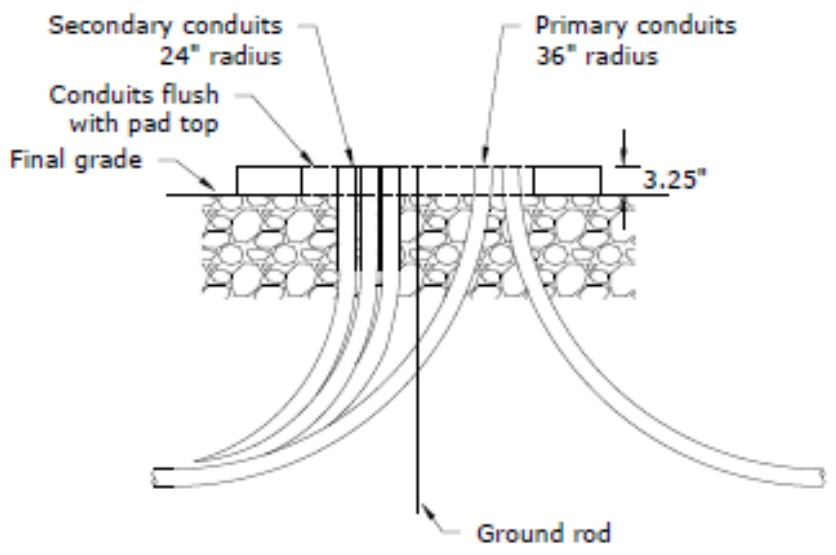

FRONT VIEW

1Ø PADMOUNT TRANSFORMER CONDUIT ORIENTATION (25-75 KVA)

- 25 to 75 kVA Pad Standard
- 100 kVA pad looks the same but is larger

Single-Phase Transformers



- Set Transformer on the pad
- Spreader bar is required to avoid door damage

Single-Phase Transformers



- Pack the sides of the pad with rock

Single-Phase Transformers

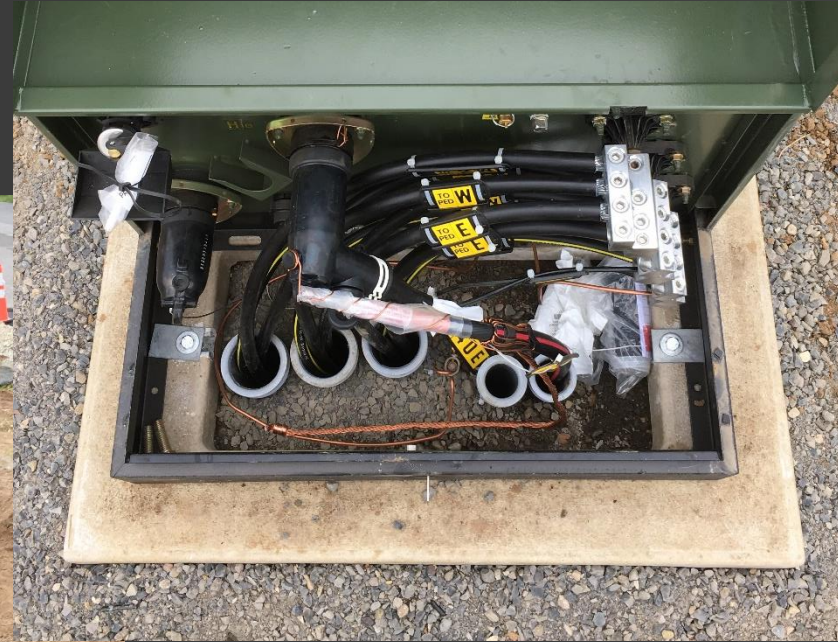

- Check for centering on the pad
- Check both the outside of the pad and the inside opening

Single-Phase Transformers



Water boxes are NOT allowed in front of transformers!

- ⦿ Uneven grade calls for a hillside barrier

Single-Phase Transformers



- Make sure to remove picking bolts
- Hillside barrier with pedestal behind

Subdivision and Apartment Conduit & Transformer Set

Single-Phase Transformers- Subdivisions and Apartments



- Conduit trees will be on the lot line

Single-Phase Transformers- Subdivisions and Apartments



- Lot numbers shall be clearly marked

Single-Phase Transformers- Subdivisions and Apartments



- Rear lot lines shall be clearly marked.

Single-Phase Transformers- Subdivisions and Apartments



● Conduit Inspection Pass

Single-Phase Transformers- Subdivisions and Apartments

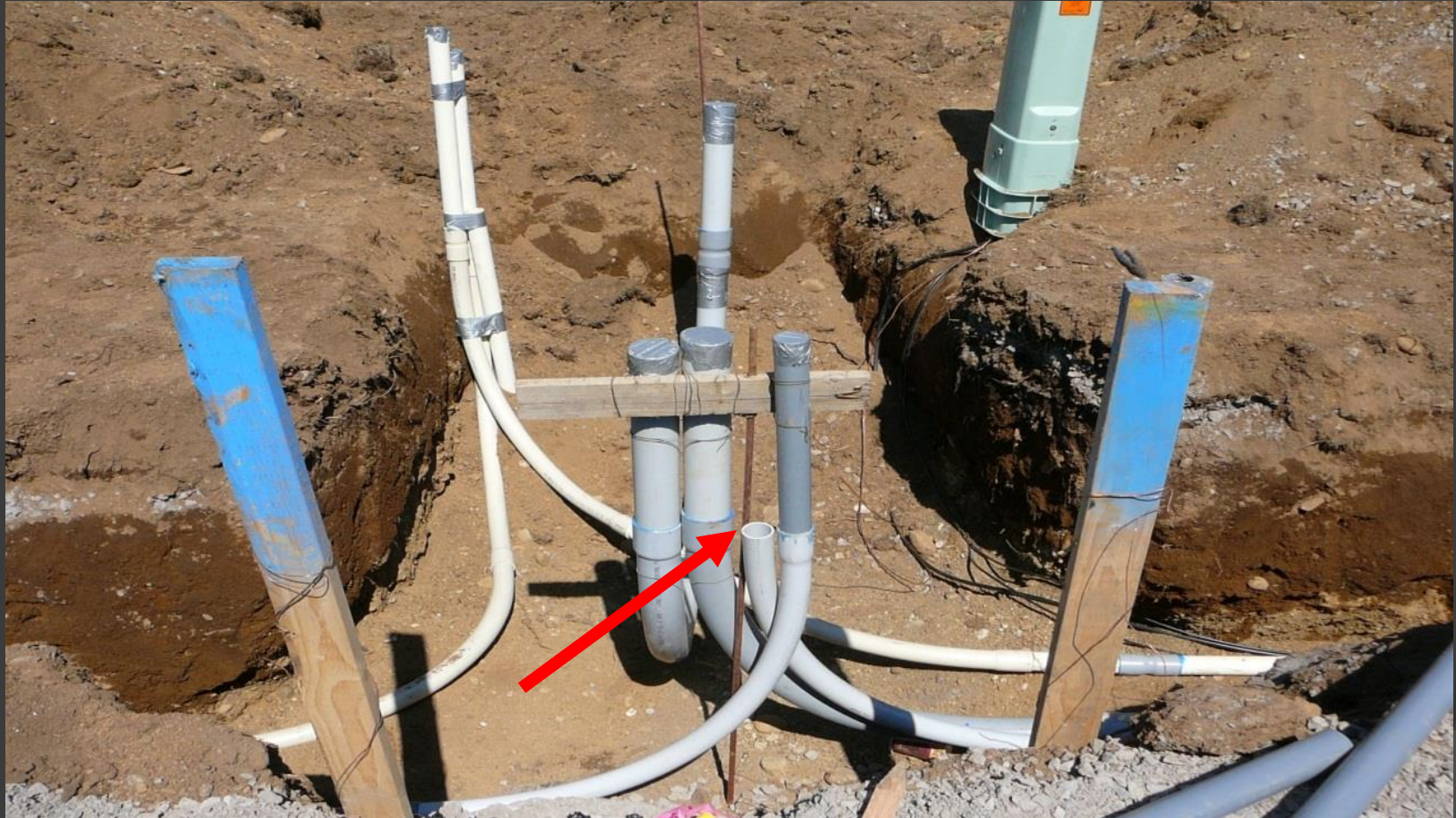

- Conduit Inspection
- Maintain separation from other utilities

Single-Phase Transformers- Subdivisions and Apartments



- ⦿ Primary in on the right
- ⦿ Primary out on the left

Single-Phase Transformers- Subdivisions and Apartments



- Minimum 1-1/2 yards gravel under the transformer pad

Single-Phase Transformers- Subdivisions and Apartments



- Compact the gravel so the transformer does not settle crooked

Single-Phase Transformers- Subdivisions and Apartments



- Remove makeup board
- Cut conduit flush with the pad
- Add end bells/collars
- Level and orientate pad square with the road

Single-Phase Transformers- Subdivisions and Apartments



- Pack sides of pad with rock

Single-Phase Transformers- Subdivisions and Apartments



- Do not leave cable exposed. Theft is common.
- Pulling cable before transformer is set is not allowed
- Use a 90 to clear out conduit and ensure equip is clean

Single-Phase Transformers- Subdivisions and Apartments



- Transformer set complete
- Streetlight next to it

Single-Phase Transformers – Subdivisions and Apartments

- ⦿ After completion of trench and conduit:
 - Call 992-8839 for a primary inspection
 - Any conduit plumbed into an energized device will require a CPU stand-by and **WILL NOT BE TERMINATED**
 - Call 992-8839 for a stand-by and primary inspection
 - A stand-by should not last longer than two hours

Secondary Makeup

Secondary Makeup

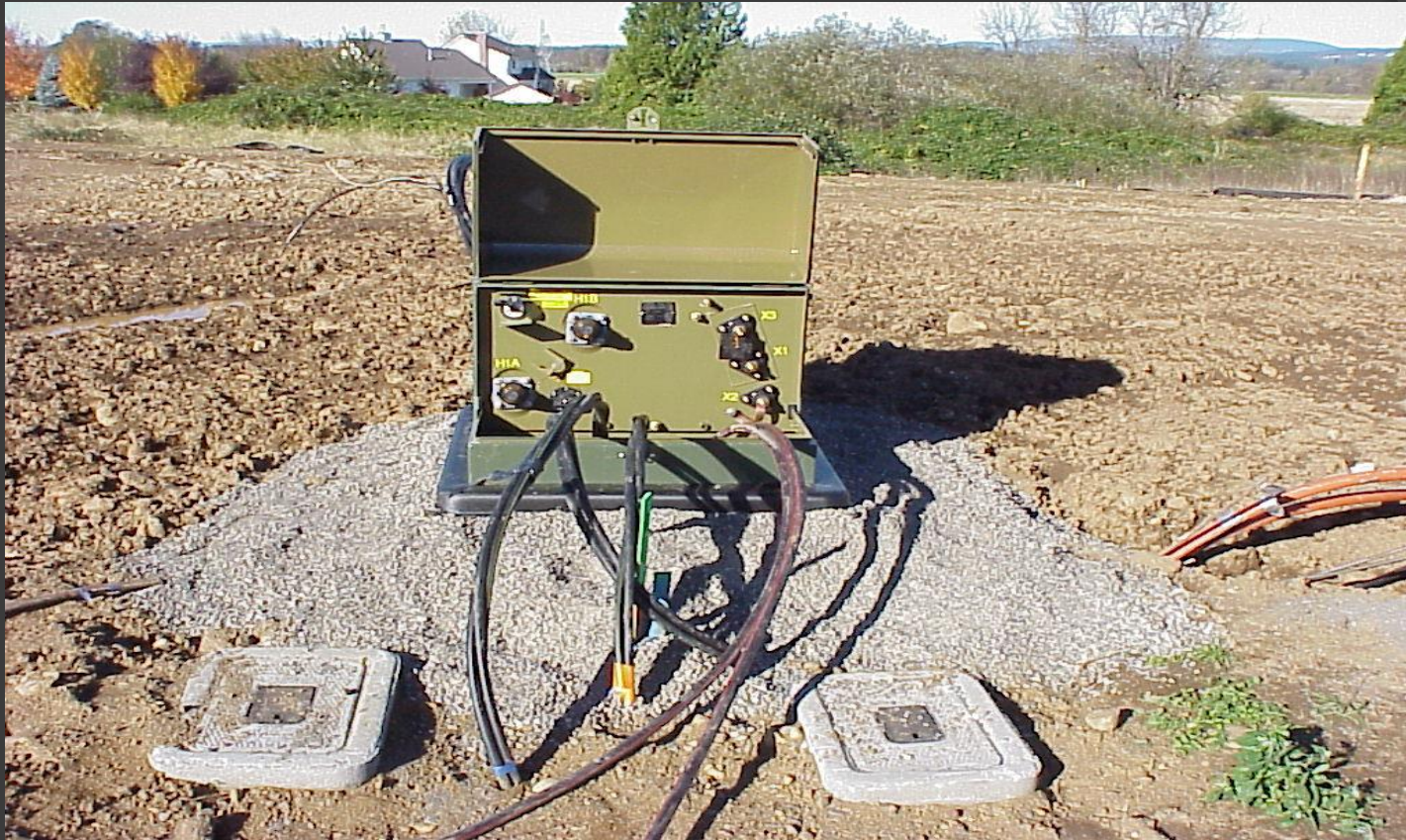

- Transformer set
- Install conduit end bells/collars
- Pull cable

Secondary Makeup

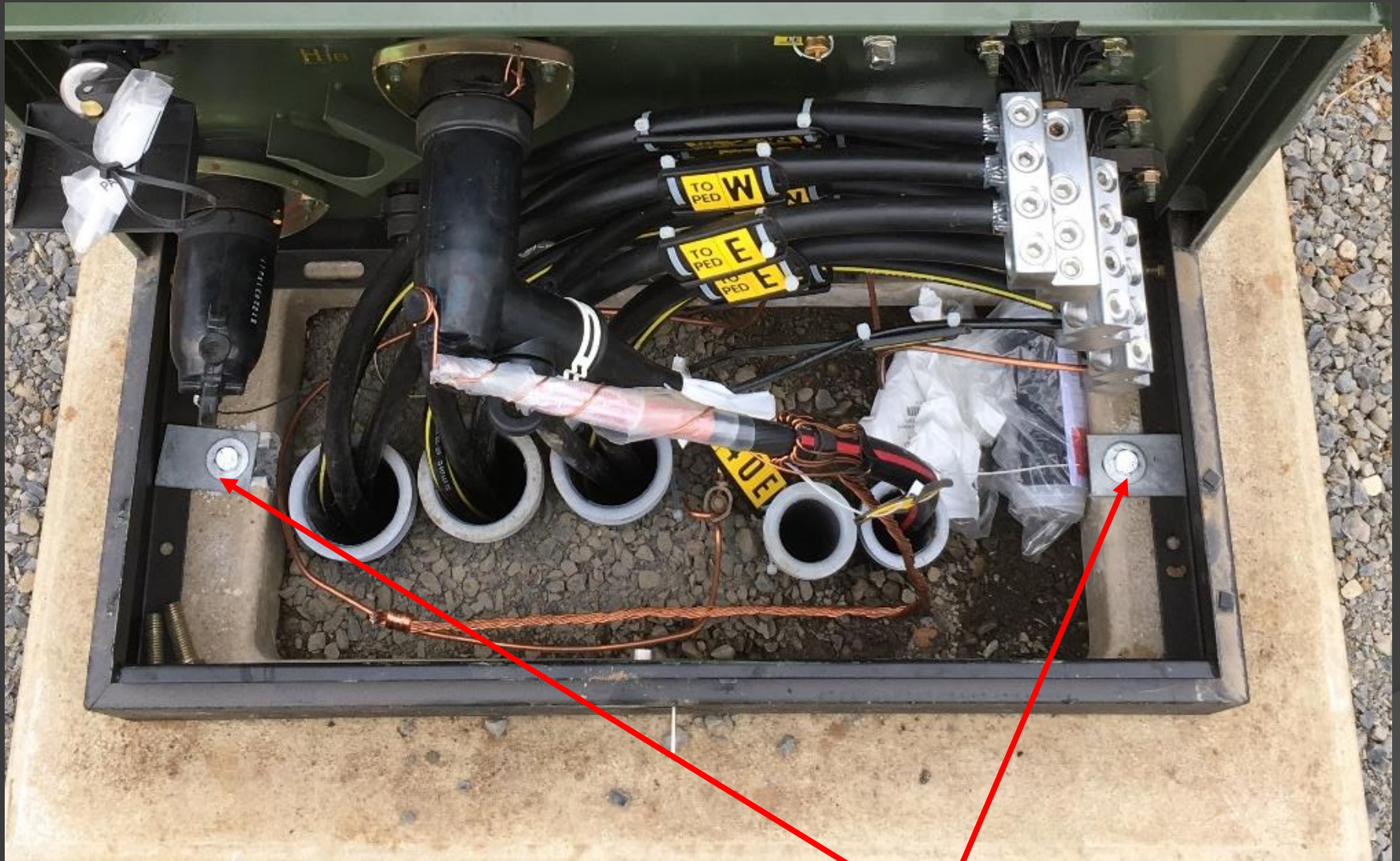

- Conduit Orientation
- Install transformer tie down on both sides

Secondary Makeup

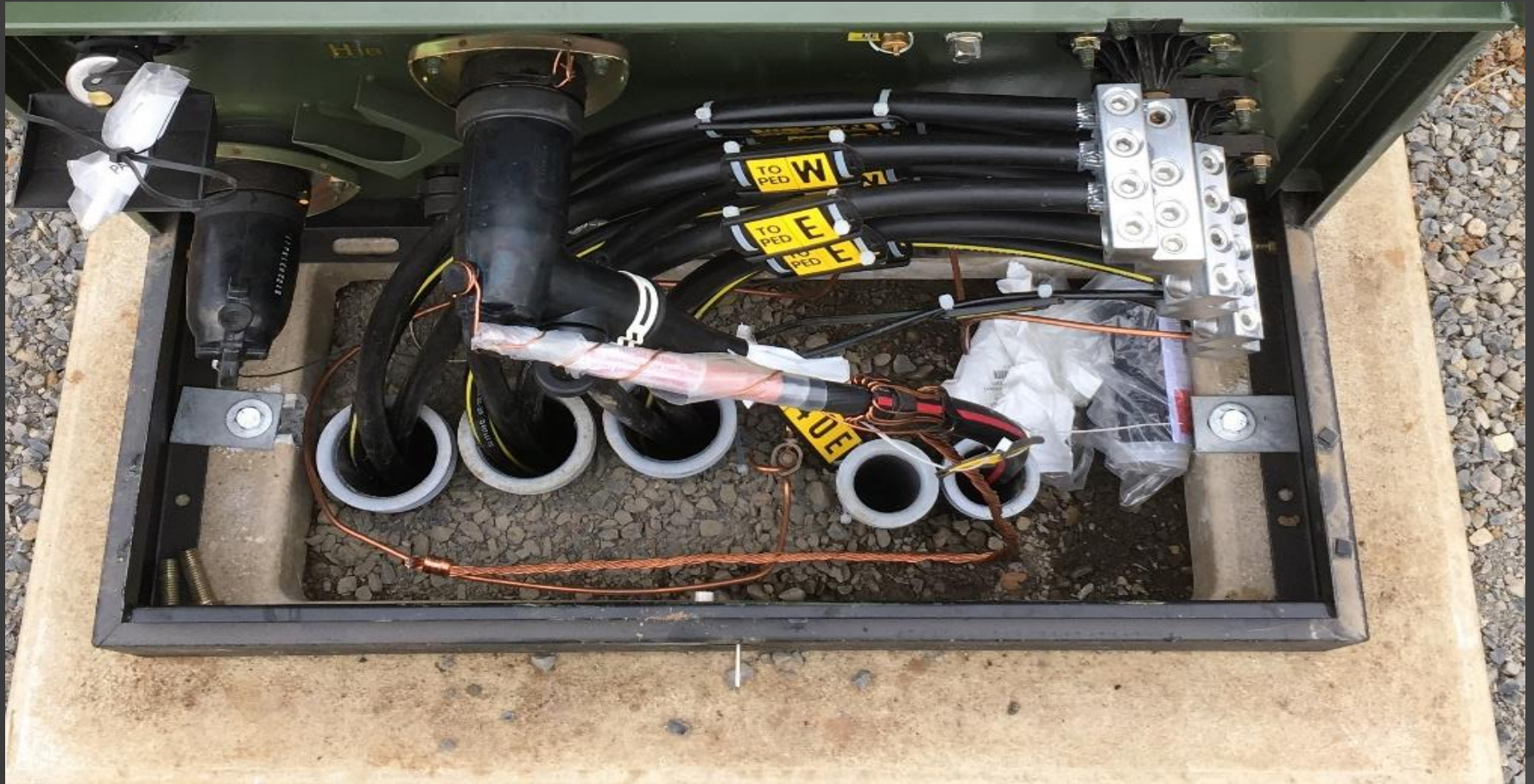

- Install z-bars (pal nuts)
- Angle each slightly for easy tool access
- Tighten down both the nut on the backside and the lug

Secondary Makeup

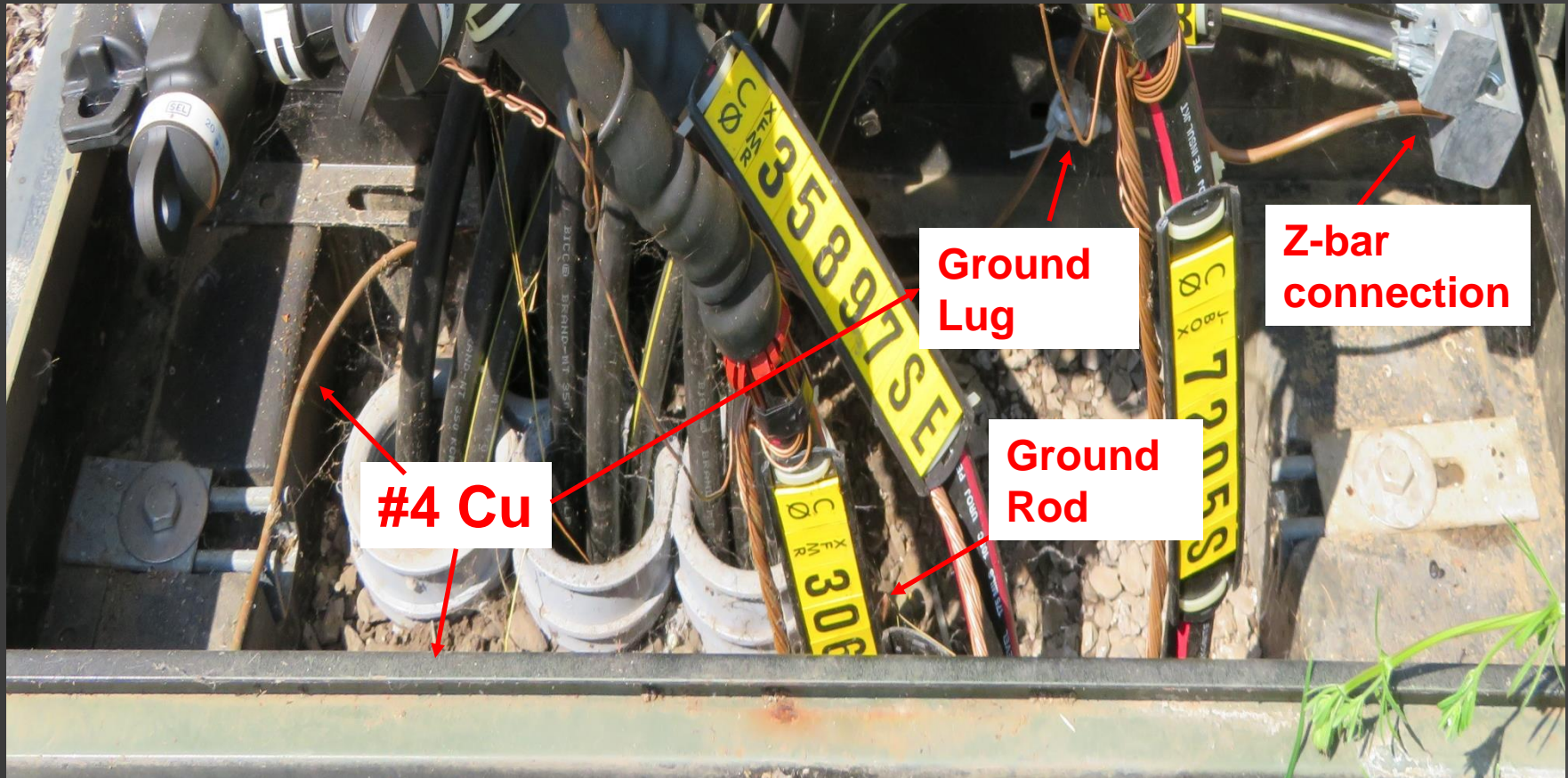

- Install transformer ground lug
- Install #4 Cu solid soft drawn
- Ground wire, around the outside of pad, to the transformer ground lug, to the z-bar

Secondary Makeup



- Train cables to their appropriate positions
- Working one service at a time will help prevent cross phase

Secondary Makeup

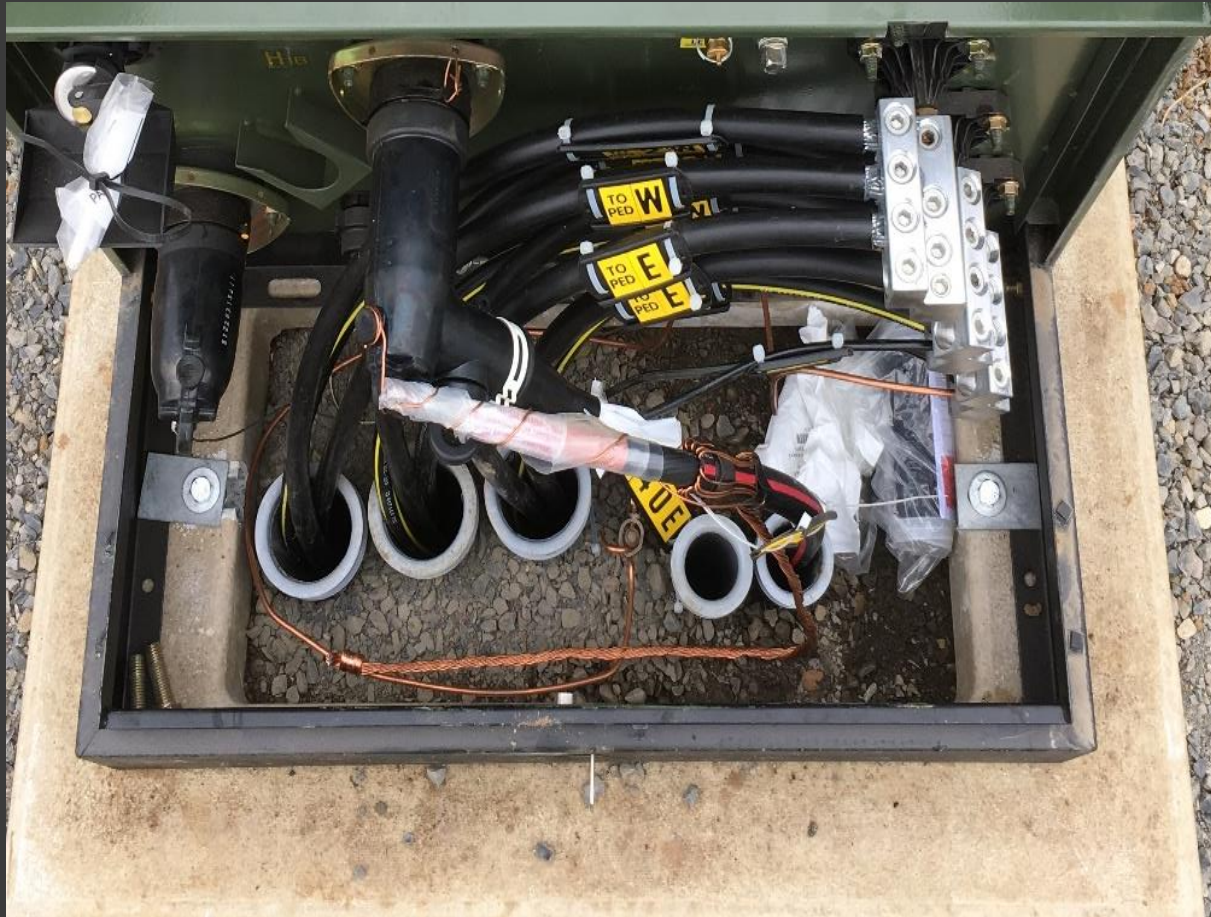

- Cut to length and skin insulation
- Cut 90 degrees
- Only skin minimal amount
- Leave slack in the cable

Secondary Makeup



- Use Penatrox if not already in z-bar
- Connect to z-bar, wiggle the wire as you tighten, hold the z-bar to support
- Tag to location (cow tags for temporary service only)

Secondary Makeup



- Start with one service
- Finish service then move on
- Work from the inside out
- Use the top of the z-bar
- Keep the cable uniform
- Tags should be visible

Secondary Makeup



- Attach tagging to every cable
- Install z-bar insulated covers

Primary Termination-Transformer

Primary Termination-Transformer

- Layers of a primary cable

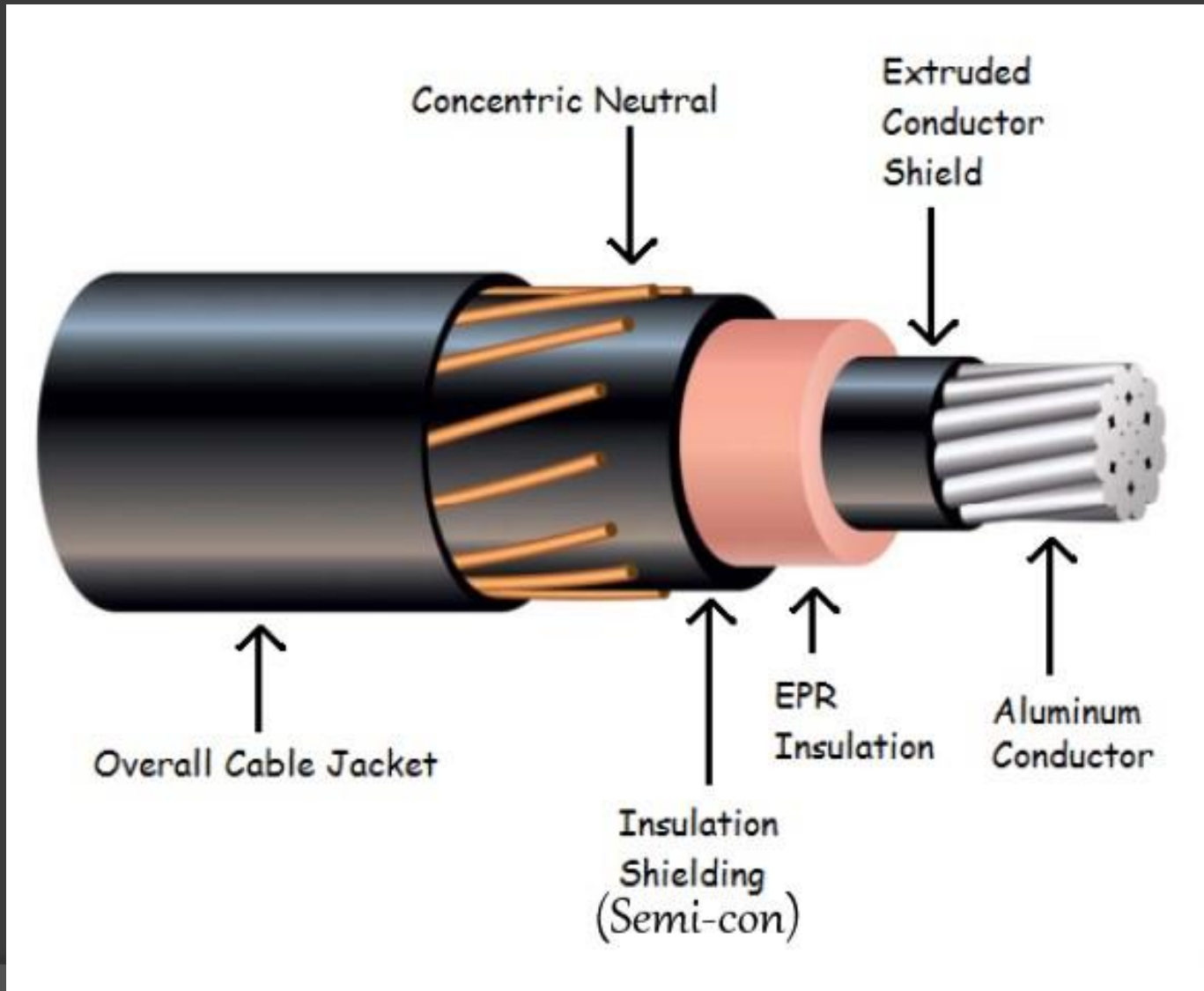

Primary Termination-Transformer

- First thing: READ THE DIRECTIONS!
 - The directions have step-by-step instructions
 - The same manufacturer can have different measurements from year-to-year
 - Ensure your tools are calibrated correctly

Primary Termination-Transformer

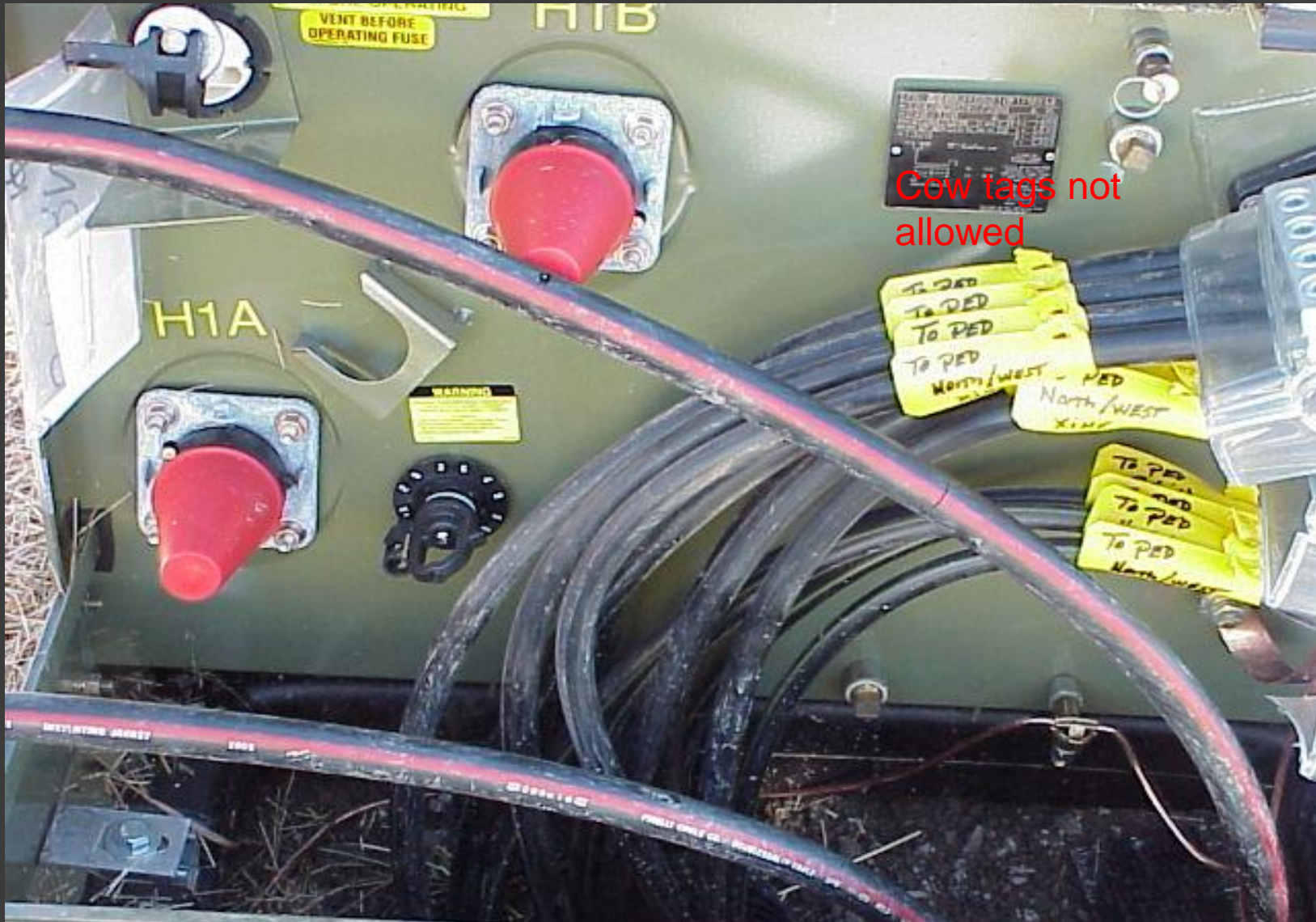

- Train the Conductor with slack

Primary Termination-Transformer



- Get your measurement from manufacturer's instructions
- Score the jacket down from the center of the transformer bushing

Primary Termination-Transformer



- Pull bleeder wire down to the score mark
- Keep it separate from other concentric

Primary Termination-Transformer



- ◎ Remove cable jacket

Primary Termination-Transformer



- Follow manufacturer's measurement from the concentric

Primary Termination-Transformer



- ◎ Cut the conductor

Primary Termination-Transformer



- Use manufacturer's measurement from the end of the cable
- Remove insulation

Primary Termination-Transformer



- Apply linket
- Align to the bushing

Primary Termination-Transformer

- Press linket
- Rotate every press 90 degrees
- Use a MD-6 press with BG dies



Primary Termination-Transformer



- Use appropriate tools to score semi-con
 - Banana peeler / Clamshell
 - Calibrate Wire Make-up tools



Primary Termination-Transformer

- Measure from the end of the lug per manufacturer's instructions
- Mark the semi-con



Primary Termination-Transformer

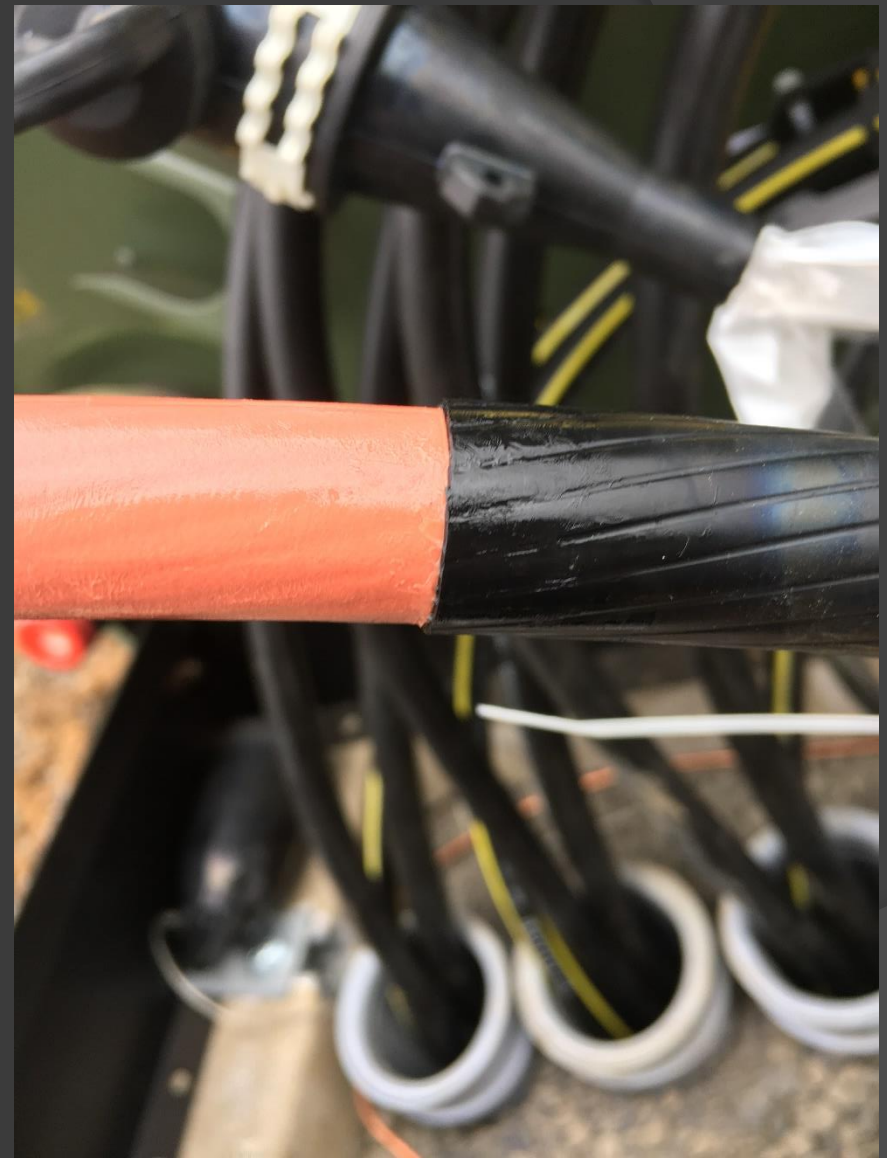

- Peel the semi-con

Primary Termination-Transformer



- Check for nicks or cuts in the insulation

Primary Termination-Transformer

Nicks and scores ruin the insulation



- ⦿ Use calibrated tools to avoid scoring insulation
- ⦿ If nicked or cut, it needs to be replaced at contractor expense

Primary Termination-Transformer



- Clean and Lubricate the bushing

Primary Termination-Transformer



- Apply ONLY the INSIDE mastic
- Fold the concentric back evenly
- Apply tape 2" down from the mastic

Primary Termination-Transformer



- Clean and Lubricate the Insulation

Primary Termination-Transformer



- Use a clear bag so inspectors do not need to remove for inspection
- Put a bag on the termination
- Wrap with the bleeder wire around the bag and through the lug
- Do not wrap bleeder too tight or excessively

Primary Termination-Transformer

Change to Integral Jacket Seal Elbow



- Two pieces to buy



- One piece to buy

Primary Termination-Transformer



- ⦿ Separate the bleeder wire
- ⦿ Twist up the neutral
- ⦿ **Do Not install the elbow on the wire**

Primary Termination-Transformer



● Press the neutrals together

Primary Termination-Transformer



- Press neutral to the ground wire

Primary Termination-Transformer



- Piggyback the termination on the elbow

Primary Termination-Transformer



⦿ Proper makeup

Primary Termination-Transformer

- After completion of Cable and Makeup:
 - Call 992-8839 for a standby and primary inspection
 - Any cable plumbed into an energized device will require a CPU stand-by and **WILL NOT BE TERMINATED**
 - A stand-by should not last longer than two hours

Primary Termination-Transformer

- 200A Hubbell Load Break elbow with integral jacket seal has recently been added to the approved material list.
- Please pay close attention to the catalog number when purchasing



* Representative image

15 kV, Load Break Elbow w/ Integral Seal, Bimetal Contact

By Hubbell Power Systems

Catalog ID: 215LEJ45

Load Break Elbow with Integral Seal, 200 Amp, 15 kV, Long Bimetal Contact, Cable Insulation Diameter range = 0.635 - 0.905 inches, 2/0 Solid or Compacted and 1/0 Stranded or Compressed

- Meets or Exceeds IEEE Std. 386 and IEEE Std. 592 requirements
- Interchangeable with other products meeting the same requirements
- Fully shielded, insulated and submersible
- Optional features include test point, integral seal, cold shrink jacket seal kit or shield adapter kit

Transformer Numbers, Warning/Danger Labels & Cable Tagging

Transformer Numbering



- Contact Construction Services (construction@clarkpud.com) for Transformer numbers
- Apply the correct number to the top left corner

Transformer WARNING Labels



! WARNING



**Hazardous voltage inside.
Will shock, burn,
or cause death.**

**If unlocked or open
Immediately call
Clark Public Utilities
360-992-3000.**

NOTICE

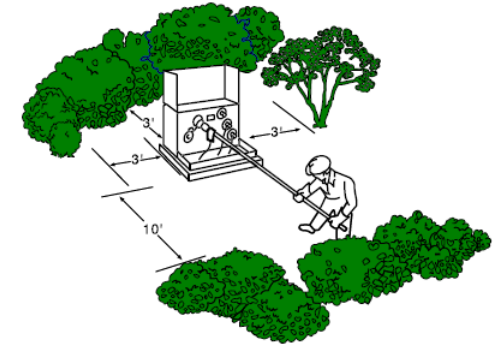

We need room to work safely on this electrical supply device.

Please keep shrubs and structures 10 ft. away from this side and 3 ft. from all other sides.

Obstructions cause delays when restoring electric service and will be removed at the owner's expense.

! CAUTION



**Know what's below.
Call before you dig.**

**UNDERGROUND POWER CABLES
ARE LOCATED IN THE AREA
CALL BEFORE YOU DIG**



**Know what's below.
Call before you dig.**

- Contact Construction Services (construction@clarkpud.com) for WARNING labels
- Apply to the front of transformers

Transformer DANGER Labels



- Contact Construction Services (construction@clarkpud.com) for DANGER labels
- Apply to the inside lid of transformers

Cable Tagging

- We require hard tagging of cables
- Tagging materials are on the Approved Material List



Primary

Secondary

In transformer to secondary pedestal.

House #
In secondary pedestal to house.

In secondary pedestal from transformer or pole.

In transformer or pedestal to streetlight.

Parallel Secondary

In secondary pedestal from transformer or pole.

In secondary pedestal to house.

Note: Zip tie **ONE** tag around each set of parallel cables.

Future Conduits (Normally Will Require Two Tag Holders)

Device #

Length of Conduit

Notes:

1. These tags are for URD primary and secondary cables. Tag all cables.
2. Parallel cables shall have one tag zip tied around both cables.

Rev 4: Added tagging for parallel conductors.

	CONSTRUCTION STANDARDS			REVISIONS		
	UNDERGROUND CONDUCTOR IDENTIFICATION TAGS			DATE	ENGR	OPS
	1	2/23/00	RWH/	MA		
	2	8/23/04	LB	AH		
	3	3/16/14	JCP	DRAFT		
4	10/3/22					

PAGE: 1 of 1	UID2	CAD FILE: xUID2	APP: DATE: 1/31/00	SECTION 1300
-----------------	-------------	--------------------	-----------------------	------------------------

APPROVED
PRIMARY ELECTRICAL
INSTALLATION



PART 2

Contractor Training Class
2024

Secondary Pedestal

Secondary Pedestal



- Tree up pipe
- Make sure it is in the exact location the print calls for

Secondary Pedestal



- Grade Pedestal to the grade line
- Ground rod is no longer required

Secondary Pedestal



- Grade only to the grade line on the outside
- Do NOT fill the inside
- Start with source cable in the second hole from back and go forward with load(s)

Secondary Pedestal



- Be careful when backfilling

Flush mount Ped (17" x 30") Make-up

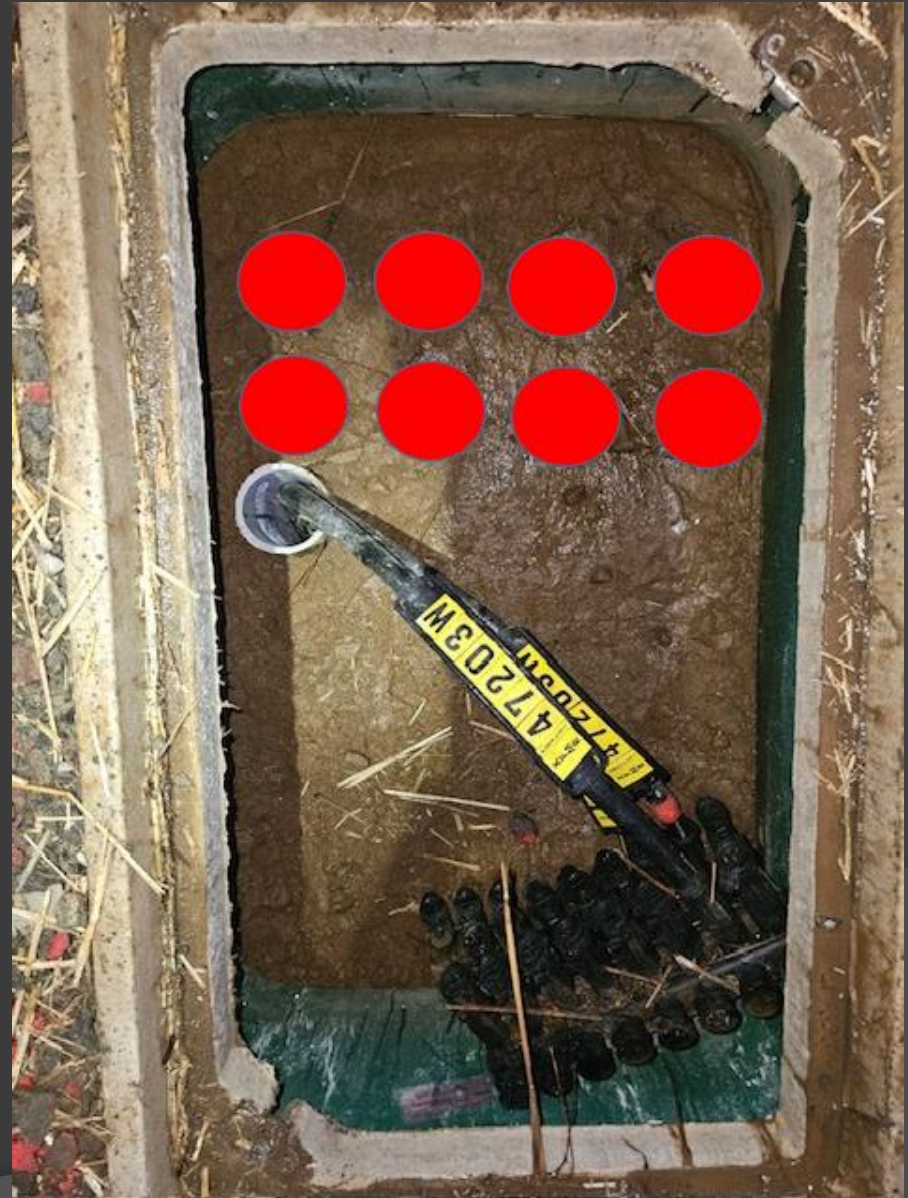

Secondary Pedestal

- Bury 14", grade should be 8" down from the lock
- Set pedestal directly behind transformer
- Set on the property line
- Installed 3 feet behind transformer
- Be aware of grade to panel

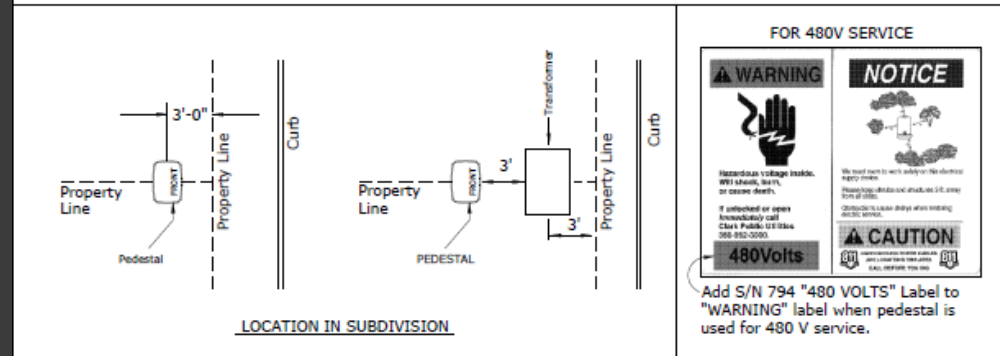
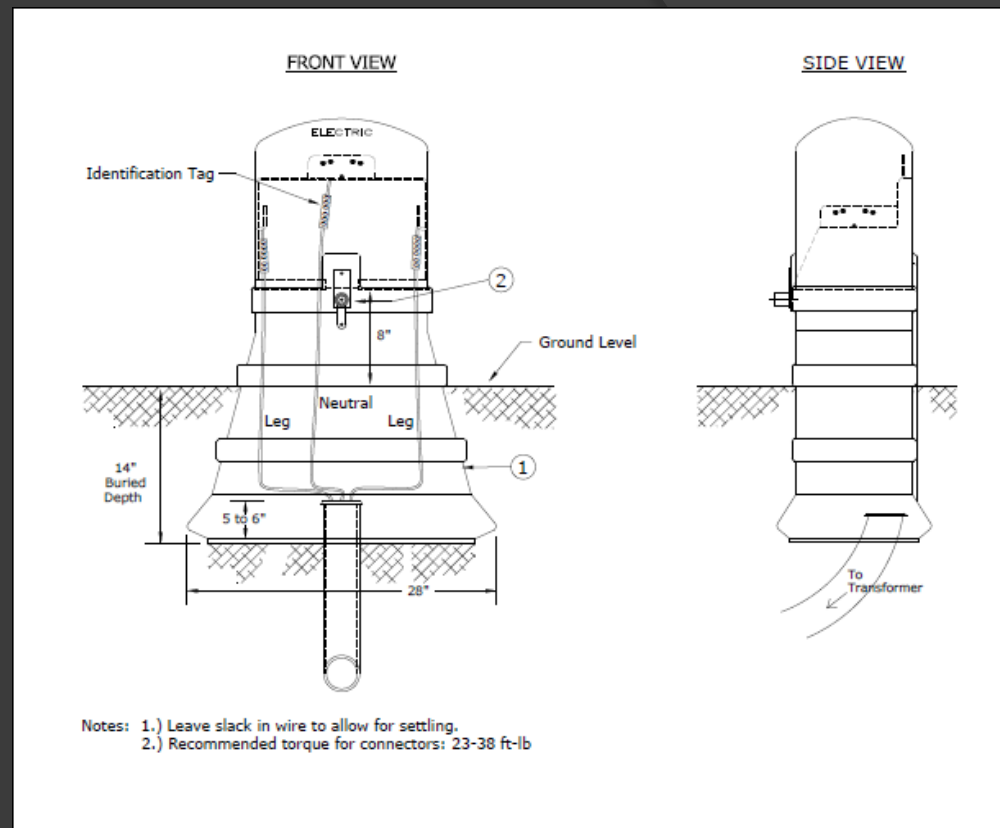

Rev. 4 - Removed ground rod for BDR.



CONSTRUCTION STANDARDS SECONDARY PEDESTAL ASSEMBLY

PAGE:
1 of 3

UED6

CAD FILE:
UED6

APP: HWH/ELM
DATE: 1980

SECTION
1700

REVISIONS

NO.	DATE	ENGR	OPS
1	4/26/04	LB	AH
2	3/12/20	KCP	
3	12/9/22	CRM	GM
4	6/7/23	CSB	

Secondary Pedestal

- Follow cable placement
- Do NOT use an impact driver/wrench to tighten connectors
- Connectors sized #10 to 350MCM

DO NOT Cut Zip Ties off Plastic PED Covers
Zip Ties **MUST** Be Reinstalled

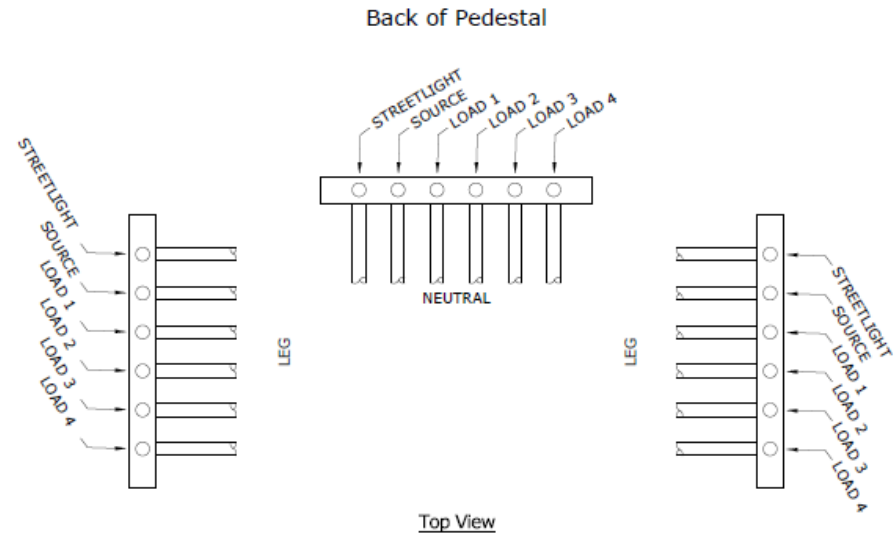

Recommended torque: 23-38 ft-lb
Do NOT Use Impact Driver/Wrench

- Notes: 1.) Maximum cable size is 350 MCM.
2.) Minimum cable size is #10.
3.) Maximum of 6 triplex cables.

Rev. 4 - Removed ground rod for BDR.

ITEM NO	DESCRIPTION	UED6	
		QTY	S/N
1	Pedestal, Secondary, Above Ground, W/ Connectors and Covers *	1	2562
2	Lock, Equipment *	1	837

CONSTRUCTION STANDARDS				REVISIONS		
SECONDARY PEDESTAL ASSEMBLY				DATE	ENGR	OPS
1	4/26/04	LB	AH			
2	3/12/20	KJP				
3	12/9/22	CRM	GM			
4	6/7/23	CSB				

PAGE: 2 of 3	UED6	CAD FILE: UED6	APP: HWH/ELM	SECTION: 1700
			DATE: 1980	



Secondary Pedestal

- Tag parallel cables with one tag
- Tag each leg individually

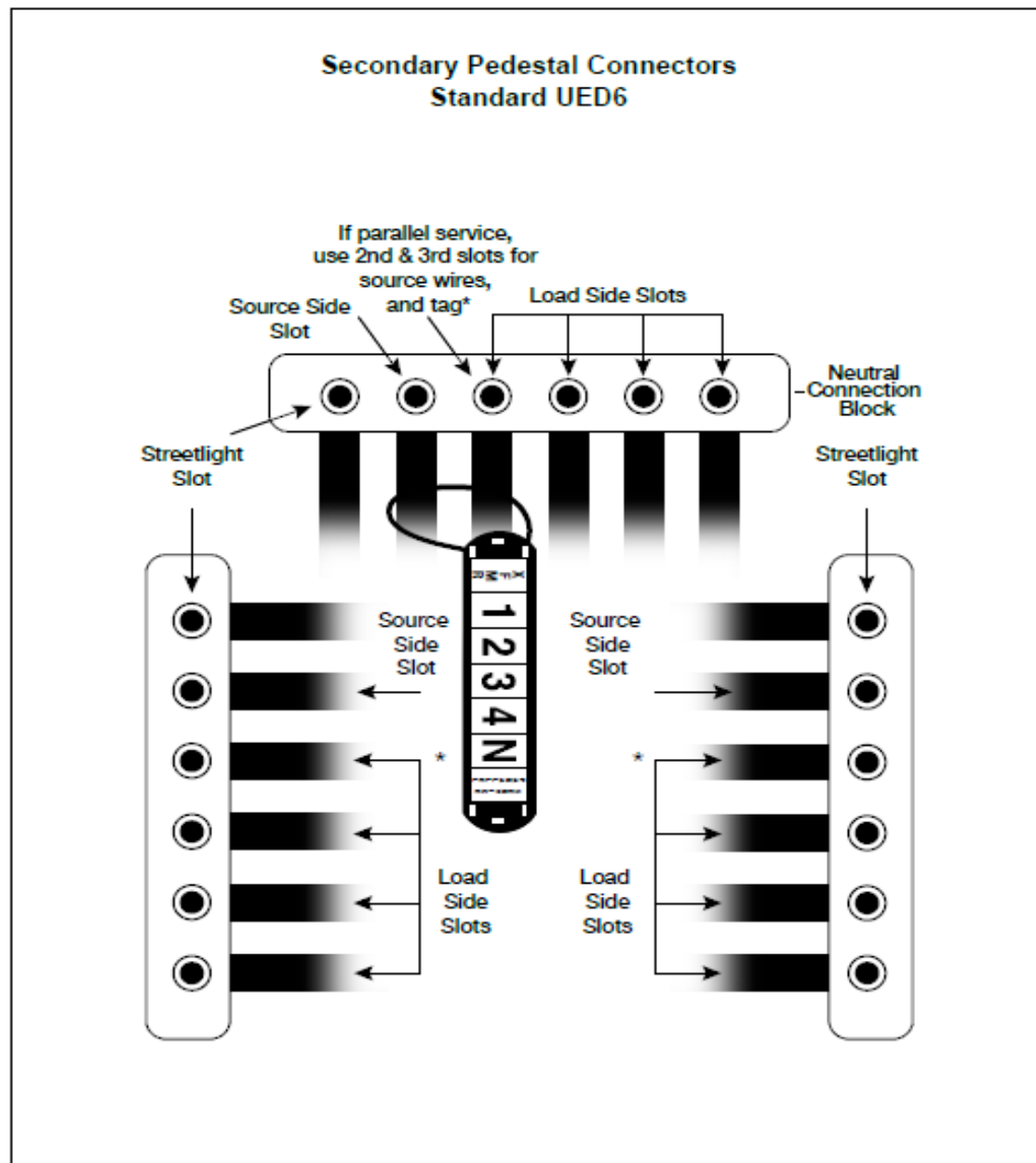

Meters

Meters

Ensure secondary is ready for our crews

Manufacturers like to include the meter rings inside the meter base. Please remove and discard as we will use our own.

Ensure secondary connections are tight



Meters



Meter Pack

- ⦿ Meter Packs must be labeled with hard plastic, metal or phenolic block labels with raised or engraved letters
- ⦿ An address/building number label is required for the building's main disconnect label
- ⦿ A permanent label is required at the meter base, corresponding breaker , electrical panel and building (HOUSE) meter
- ⦿ Minimum of ½-inch height letters are required for all metering equipment labels
 - <https://www.clarkpublicutilities.com/wp-content/uploads/2021/10/Multi-Meter-Labeling-Detail.pdf>

Meter Pack

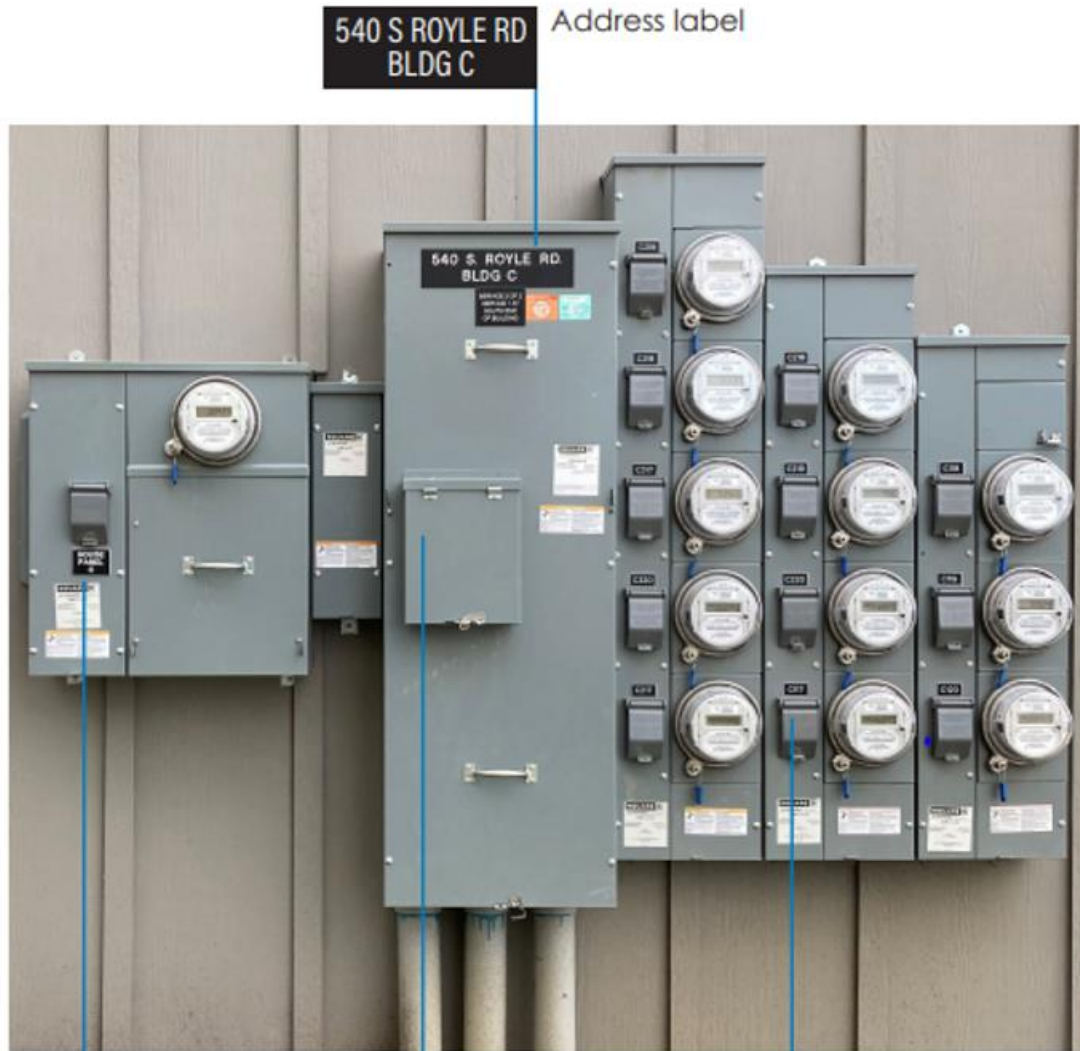

540 S ROYLE RD
BLDG C Address label

HOUSE
PANEL
C

Building meter
labeled 'HOUSE'

Disconnect
required if
more than
6 meters

C117

Adjacent meter

Meter Pack



- You must have permanent meter equipment labeling and an electrical inspection before CPU will energize the meter base and set meters

Streetlights

City Streetlight Ownership & Maintenance

◎ Not Maintained by CPU - Vancouver/Camas

- All street lights are owned and maintained by the Cities of Camas and Vancouver
- Most lights are direct feed off CPU's system
- UG streetlight wire is maintained by CPU, the fixtures and poles are city maintained
- New installations require a disconnect, installed to the NEC, and the City owns and maintains all equipment

◎ Maintained by CPU - All Other Cities (Battle Ground/ Ridgefield/ La Center/Yacolt/ Washougal)

- All street lights owned by the Cities
- Street lights directly fed off CPU's system are maintained by CPU
- All direct feeds owned and maintained by CPU
- Newly installed street lights are directly sourced by CPU

Streetlights



- Streetlight standards must be positioned according to the design print

Streetlights



- Example of a streetlight conduit that is treed up
- Notice this ditch has been partially back filled and the gas line is installed

Streetlights



- Position the light to the correct spot
- CPU spec is 100% conduit
- Backfill around the base

Streetlights



- Compact around the base as you backfill

Streetlights



◎ Backfill to the final grade

Streetlights



- Install the Light and Arm
- Run the wire from the light down to the base of the standard

Streetlights



- ⦿ Make the neutral connection
- ⦿ Make the phase connection using a fuse
- ⦿ Attach the hand hole cover plate

Streetlights - Aluminum Poles

- Aluminum poles require ground rod
- Run #6 Cu from ground lug in pole to ground rod

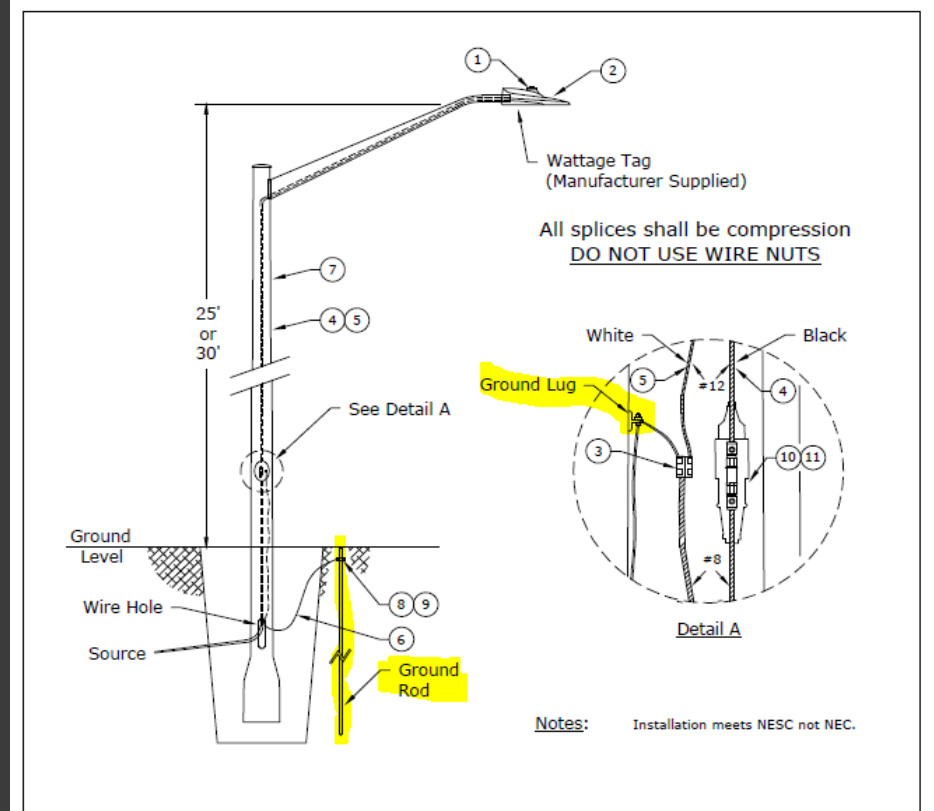

ITEM NO	DESCRIPTION	SL100ALED		SL200ALED	
		QTY	S/N	QTY	S/N
1	Photoeye, LED and HPS, 120V, 3-pin	1	2872	1	2872
2	Luminaire, Cobrahead, LED, Type 3, 3000K, HPS Equivalent	1	2889	1	2895
3	Connector, H-Tap, Al/Cu, Run #6-#2 Str, Tap #14-#8 Str	1	416	1	416
4	Cable, 600V, Cu, #12, 19-Str, Black, 1C	42 ft	386	42 ft	386
5	Cable, 600V, Cu, #12, 19-Str, White, 1C	42 ft	387	42 ft	387
6	Conductor, Cu, #6, Solid, Bare, Soft Drawn, 1C	2 ft	374	2 ft	374
7	Pole, Streetlight, Al, Direct Burial, 25' Mounting Height w/ 6' Arm	1	2946	-	N/A
7	Pole, Streetlight, Al, Direct Burial, 30' Mounting Height w/ 6' Arm	-	N/A	1	2945
8	Clamp, Ground Rod, 5/8", Bronze, Small	1	281	1	281
9	Rod, Ground, 5/8" x 8'	1	1124	1	1124
10	Fuse, 10A, 250V, Time Delay, Streetlight	1	2389	1	2389
11	Holder, Fuse, Streetlight	1	2388	1	2388



CONSTRUCTION STANDARDS

STREETLIGHT, 100/200W EQUIV. LED COBRAHEAD
SINGLE ARM
ALUMINUM POLE, DIRECT BURIAL

PAGE: 1 of 1	APP: DMK/KJP	SECTION: 1000
DATE: 4/1/22	DATE: 4/1/22	

REVISIONS		
DATE	ENGR	OPS

Streetlights



- Example of a decorative streetlight standard
- Notice the base is flush to the ground

Streetlights

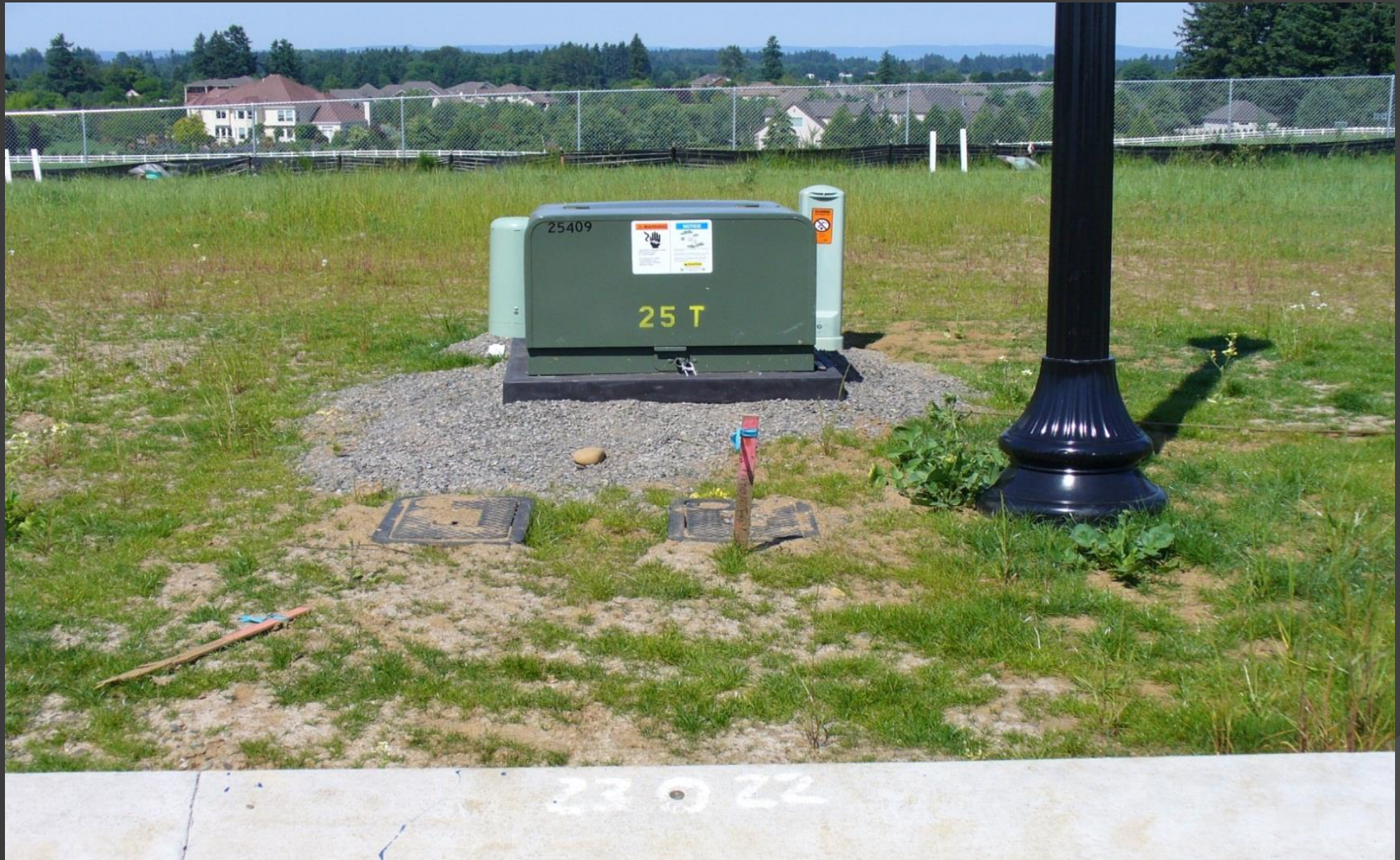

- An example of a finished streetlight installation

Three Phase Transformers

Three Phase Transformers



- ⦿ Primary conduit treed up
- ⦿ Attach it to a make up board

Three Phase Transformers



- Bring in the secondary pipe and attach it to the board
- Primary will be on the left and secondary will be on the right

Three Phase Transformers



- ⦿ Remove tree bracket and begin to backfill
- ⦿ Backfill under concrete pads must be 5/8" rock
- ⦿ Plug the end of the pipe

Three Phase Transformer

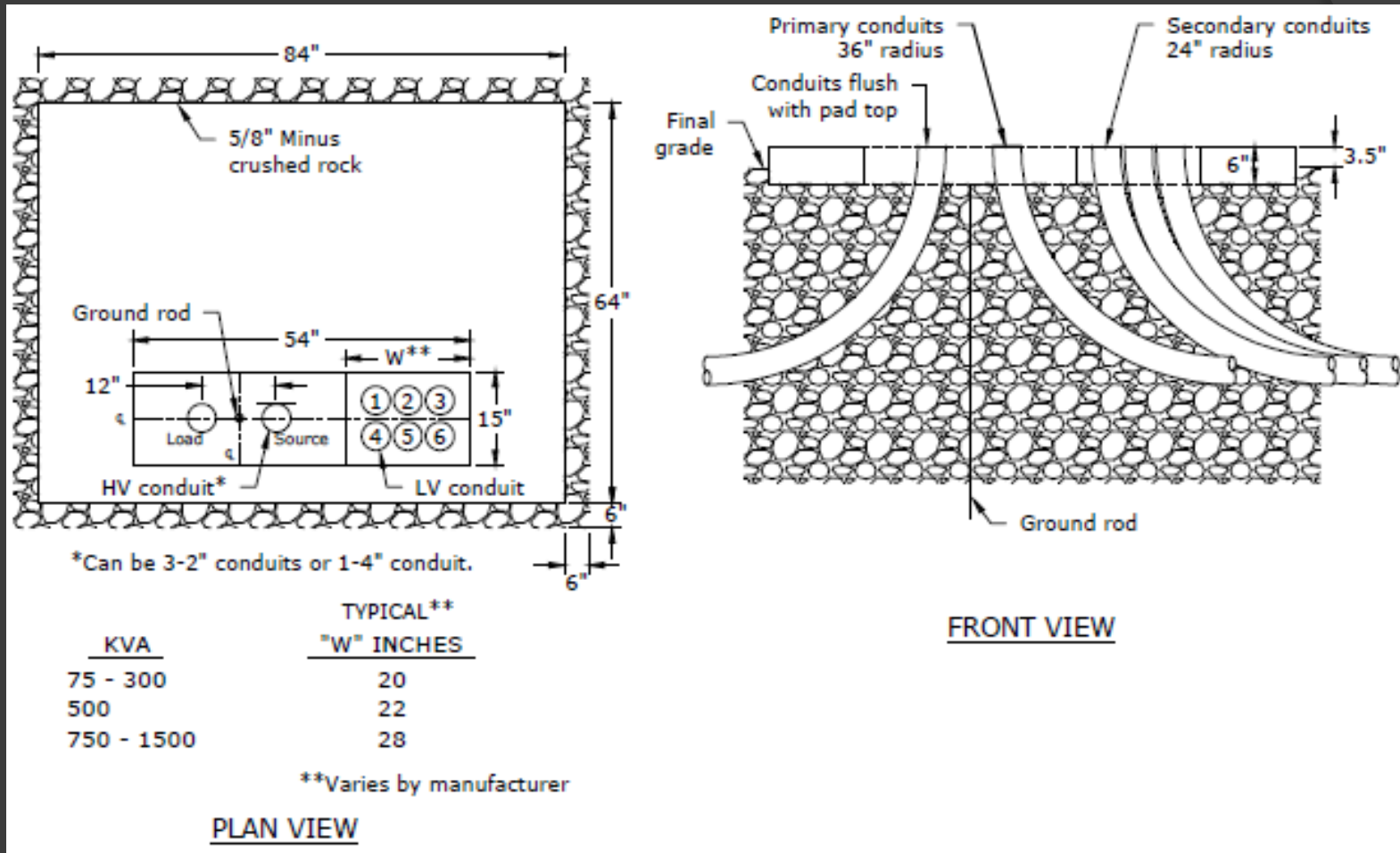

- Diagram of a 3-phase transformer layout
- Primary source on the right and the load is on the left

Three Phase Transformers



- After grade is established install the concrete pad
- Cut the conduit flush with the pad
- Install conduit end bells/collars

Three Phase Transformers



- ⦿ Install the transformer
- ⦿ Make sure it is square on the pad

Three Phase Transformers



- Example of a secondary compartment
- CPU prefers conduit plugs instead of duct tape

Three Phase Transformers



- Proper make up of radial three phase transformer
- The phasing will be left to right A,B,C,C,B,A

Three Phase Transformers

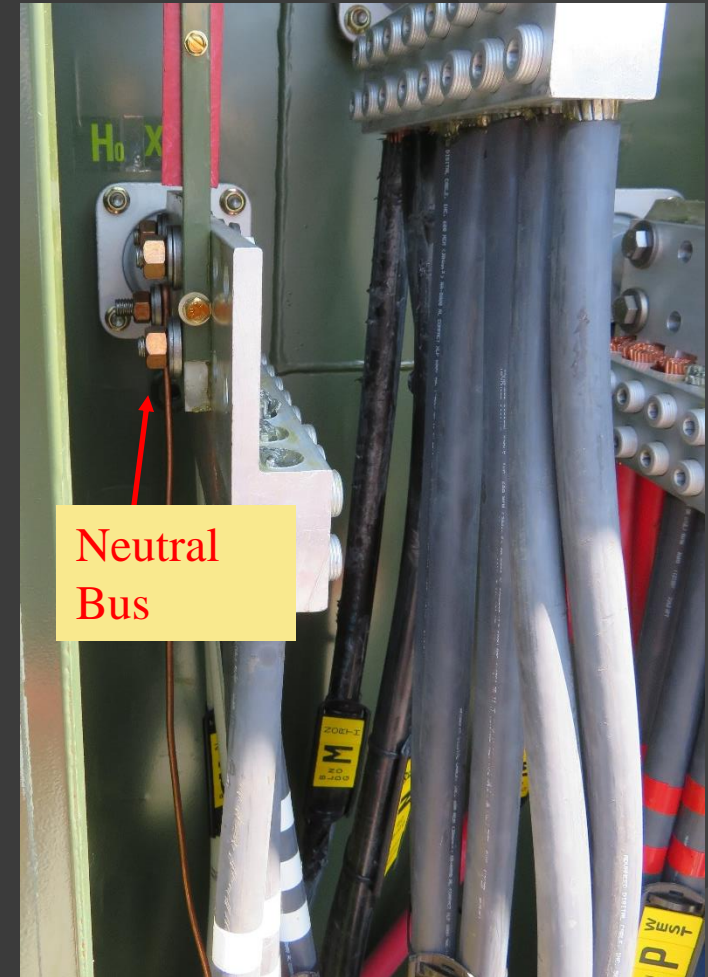
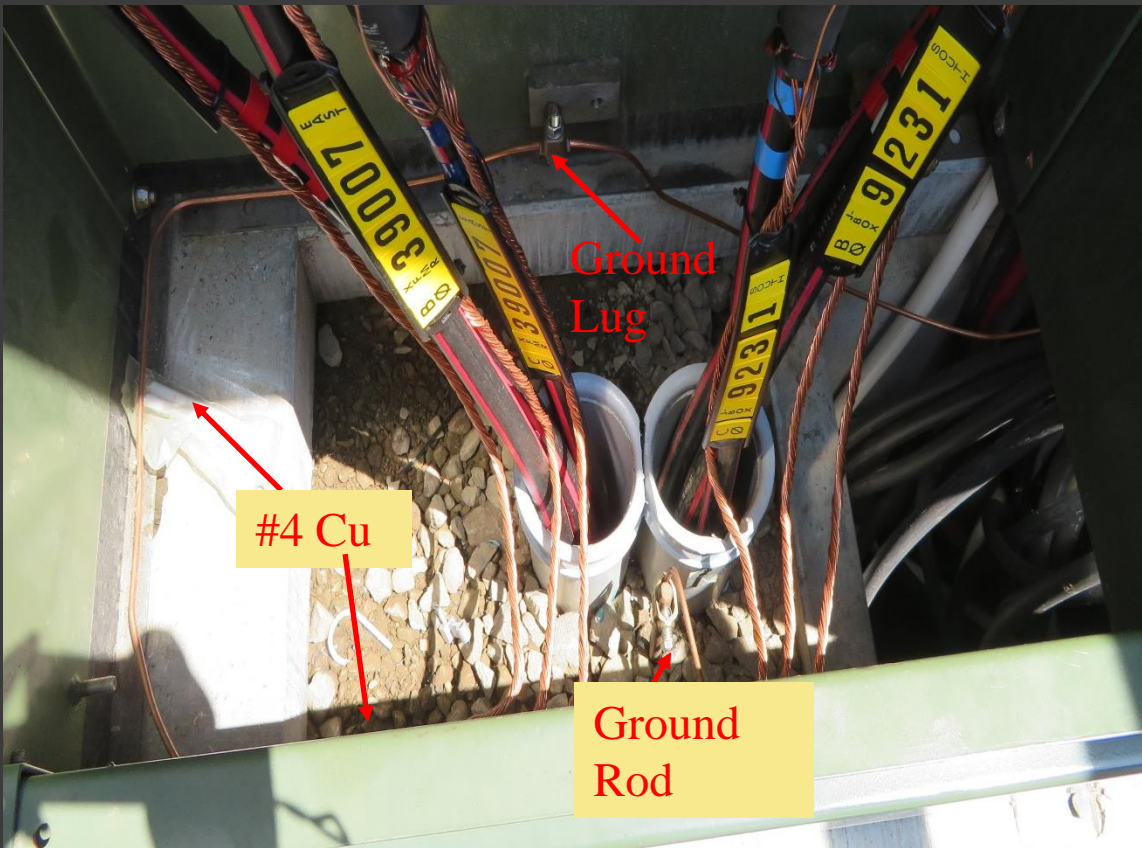

- Install #4 CU from the ground rod around the cabinet to the ground lug then to the secondary neutral bus

Three Phase Transformers



- Stub up a tail to connect the dust cover bleeder wires

Three Phase Transformers

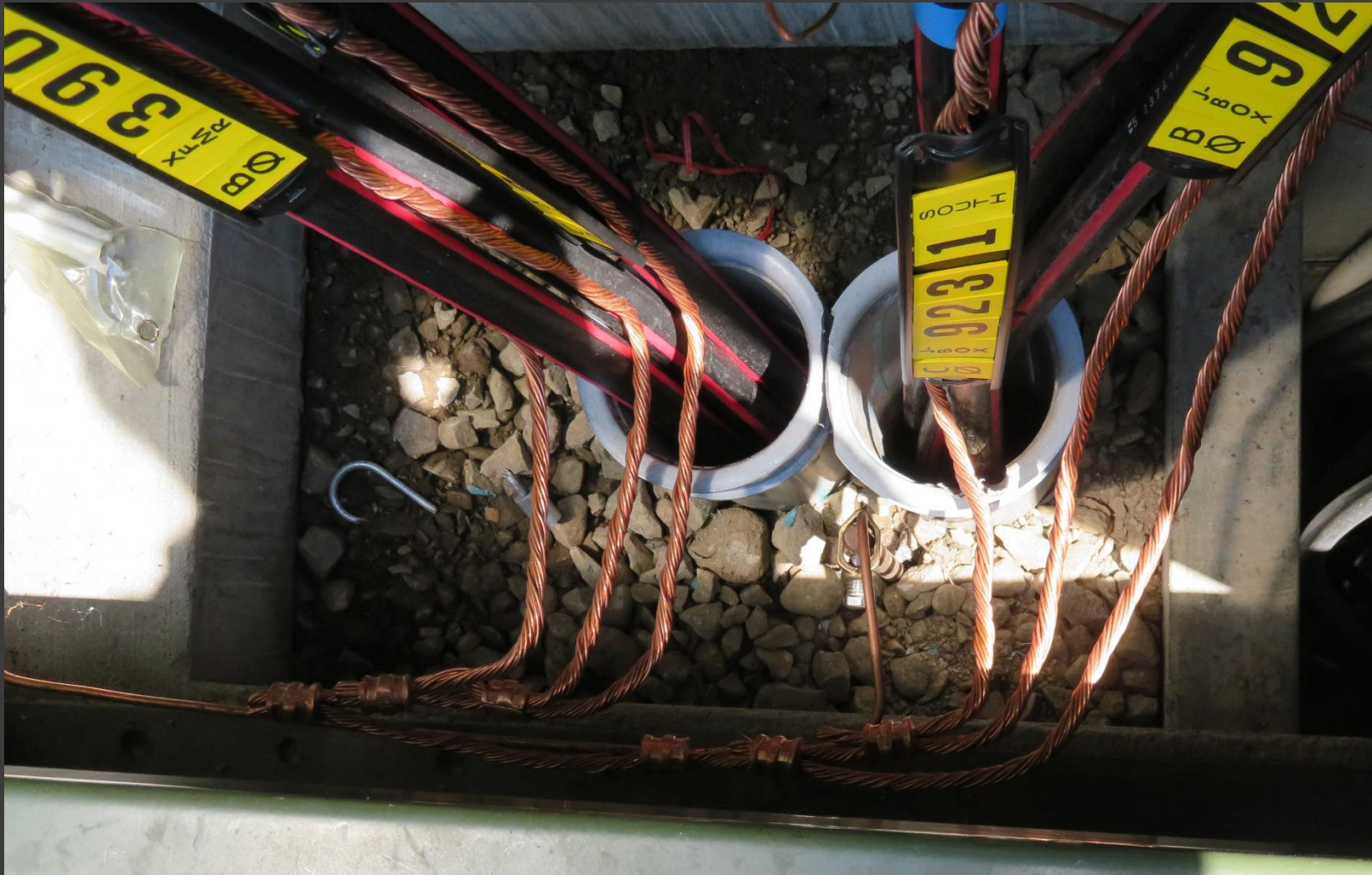

- To make up multiple primary neutrals, piggy back the concentric then connect to the ground wire

Three Phase Transformers

- This is Std UT30 - radial
- The phase labeling must align
- Make sure to tape Red, White, Blue- A,B,C (Extremely Important)

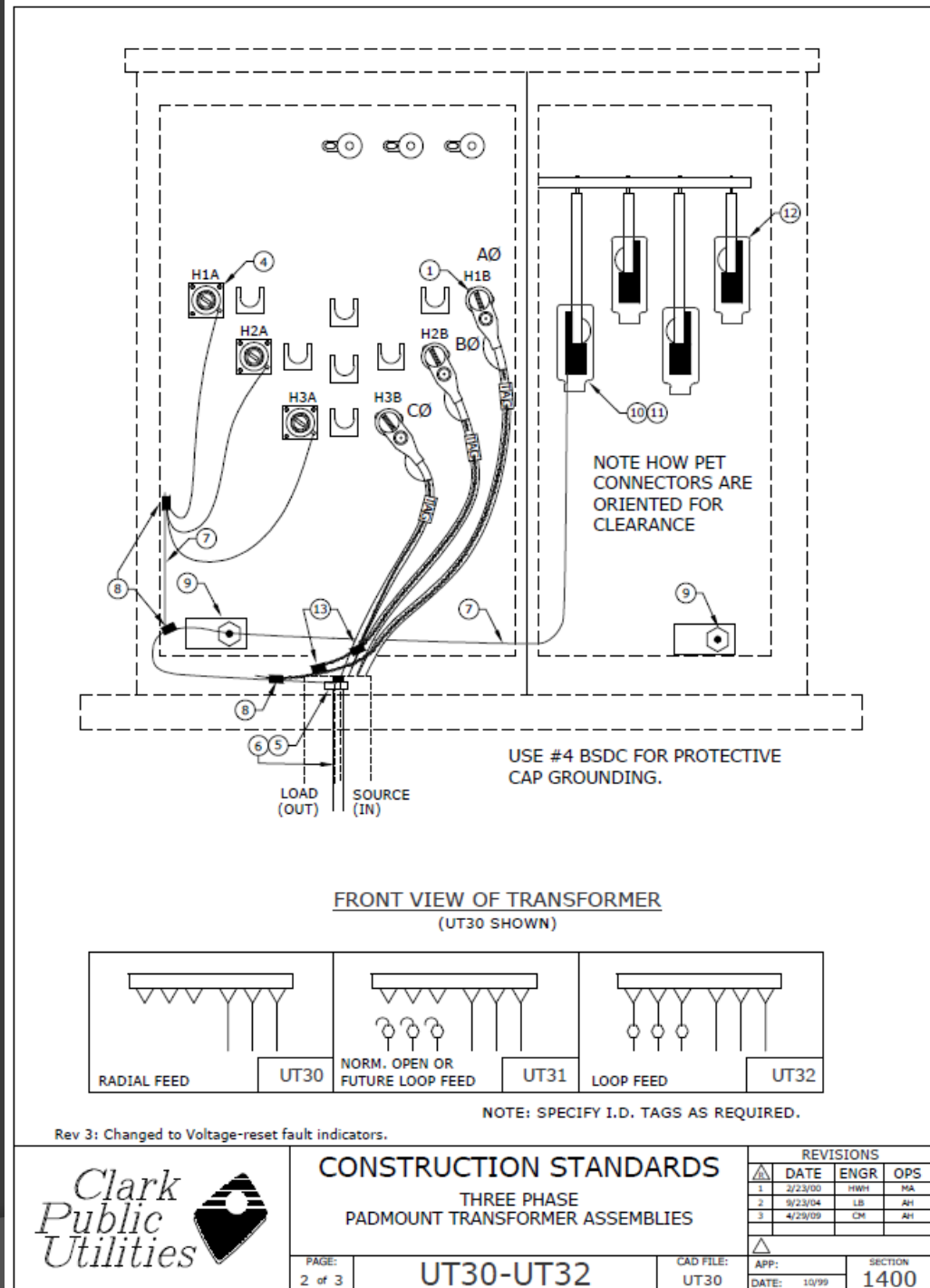

Three Phase Transformers

- This is Std UT33 – feed-thru
- The phase labeling must align
- Make sure to tape Red, White, Blue- A,B,C
(Extremely Important)

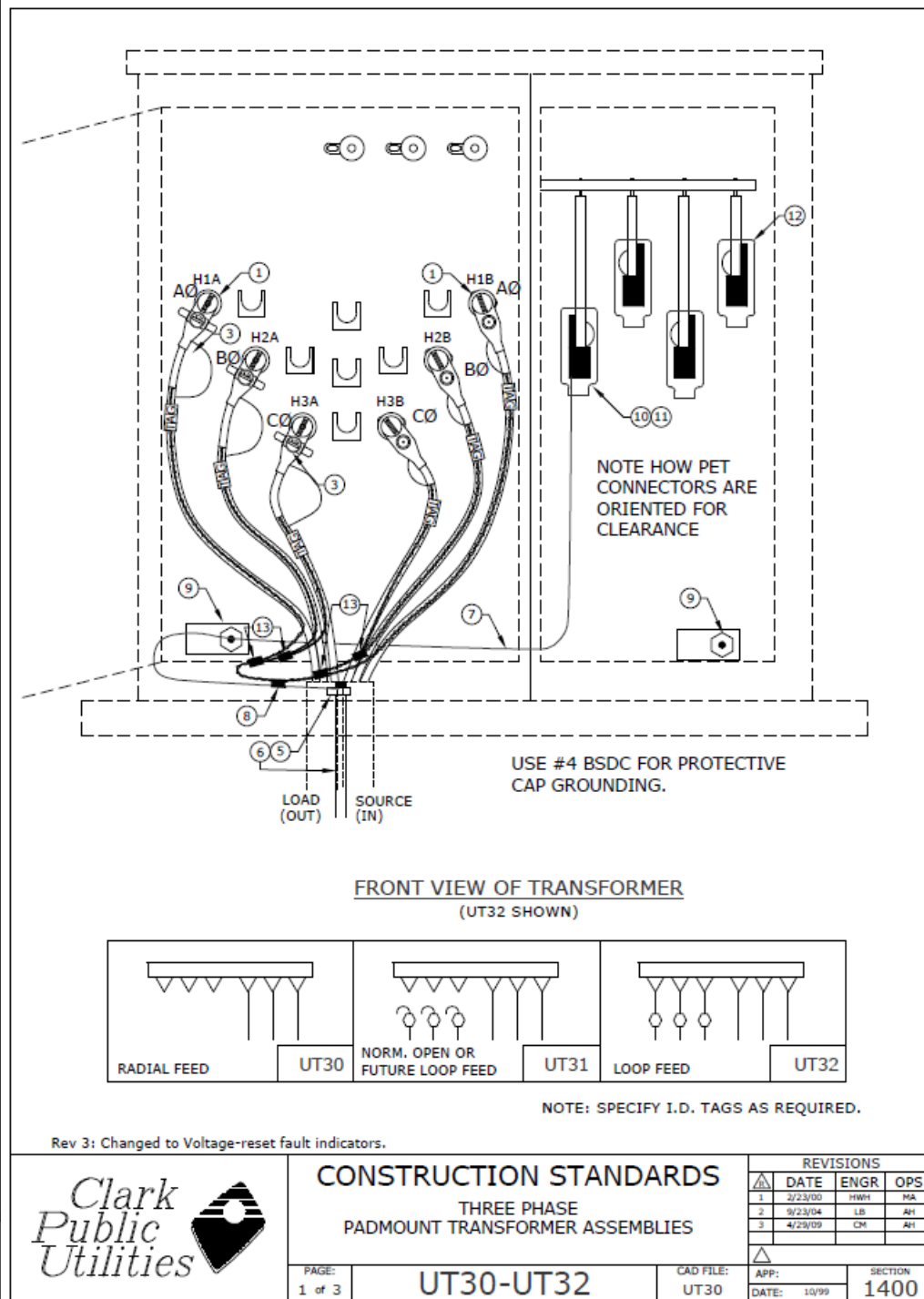

Three Phase Transformers

- ⦿ This is a picture of a feed-thru primary
- ⦿ The load side has fault indicators



Three Phase Transformers

- ⦿ This is a picture of 208v secondary make up
- ⦿ It is taped white-neutral, black-x1, red-x2, blue-x3



Three Phase Transformers



- ⦿ This is a picture of 480v secondary make up
- ⦿ It is taped white-neutral, brown-x1, orange-x2, yellow-x3 (BOY)
- ⦿ **Needs hard tagging**

Three Phase Transformers

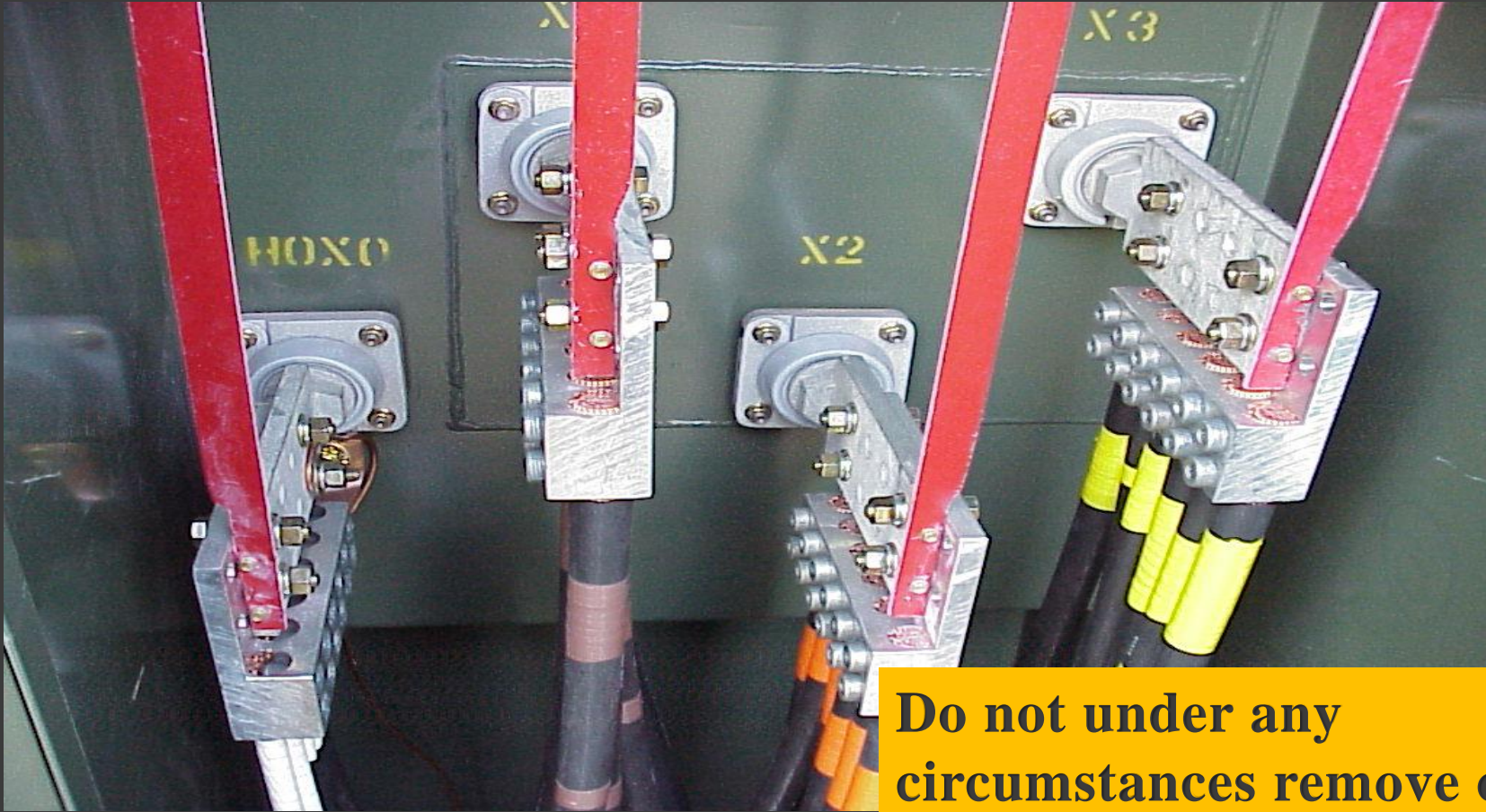

Do not under any circumstances remove or adjust the stiffeners.

- PETs will be attached
- Stiffener brackets will be installed on $\geq 500\text{kVA}$
- Every connection will have Penetrox

Three Phase Transformers

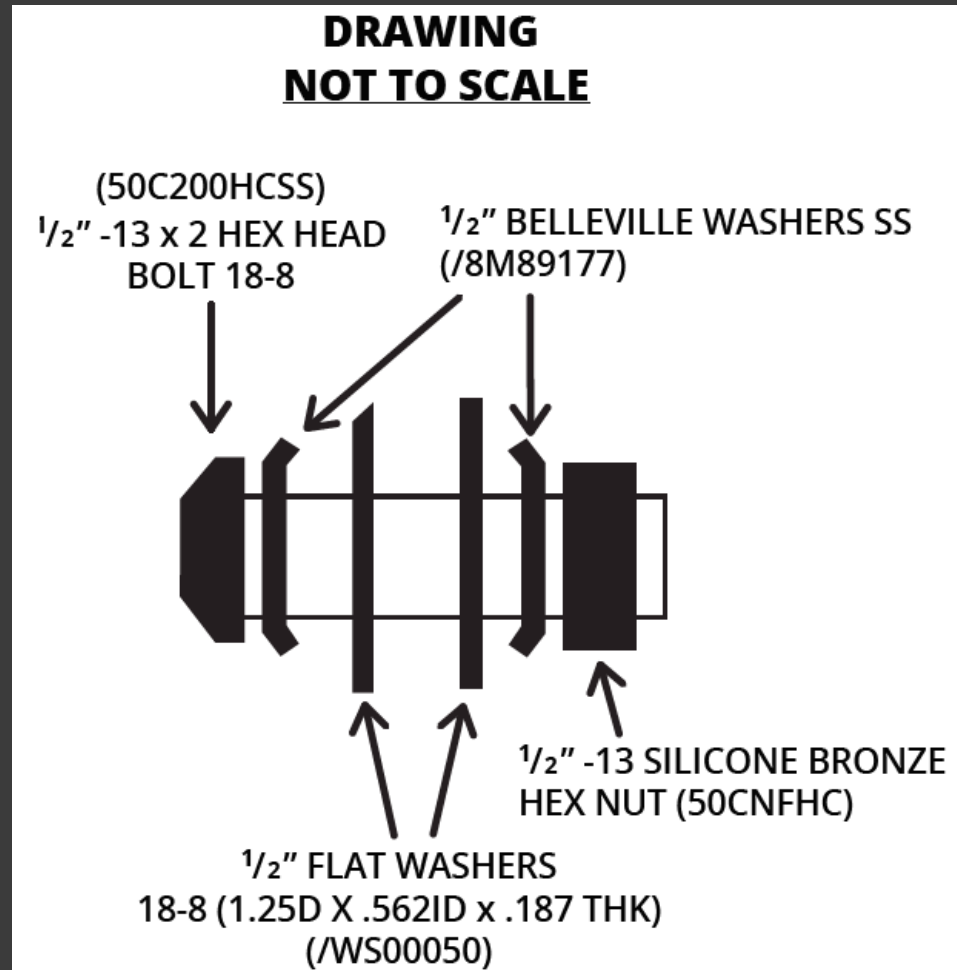

- This is an example of the stainless steel bolt assembly required to attach PETs

Three Phase Transformers

- Install insulated coverings
- If stiffeners are installed, slice the cover prior to installation – **DO NOT ADJUST OR REMOVE STIFFENERS!!!!**



Three Phase Transformers



- Example of a level transformer with good grading
- Notice the CPU Transformer #, warning label and voltage stickers

Three Phase Transformers



- Removable protective barriers need to be installed where there is traffic near a transformer
- Transformer also has a secondary vault

Single Phase J-Box

Single Phase J-Box

- Construction standard for a single phase J-box

Notes:

- TYPICAL ELBOW ARRANGEMENT IS SHOWN.
- DO NOT PUT DIRT INSIDE JUNCTION BOX. SPACE IS REQUIRED FOR CABLE SLACK AND OPERATING CLEARANCE.
- LEAVE CABLE SLACK FOR FUTURE OPERATIONS.

LEGEND:

- FAULT INDICATOR
- NORMALLY OPEN (ON STANDOFF BRACKET)

Rev 4: Changed to Voltage-reset fault indicators and added equipment lock.

UJM4	UJM41	UJM42	UJM43	UJM44	UJM45	UJM46	UJM47	UJM48	UJM49

ITEM	MATERIAL LIST DESCRIPTION	QTY	S/N
1	Ground Rod 5/8" x 8'	1	1124
2	Clamp, Ground Rod 5/8", Small	1	281
3	Junction Box, 1Ø	1	194
4	Equipment Lock, UG	1	837

REVISIONS			
DATE	ENGR	OPS	
2/23/00	HHW	MA	
9/23/04	LB	AH	
12/29/04	LB	AH	
4/29/09	CM	AH	

CONSTRUCTION STANDARDS

PRIMARY JUNCTION BOX
SINGLE PHASE

APP: JEH SECTION: UJ1

DATE: 3/22/00 1500

PAGE: 1 of 2

UJ1

CAD FILE: UJ1

Single Phase J-Box

- Construction standard for a single phase J-box, vertical view

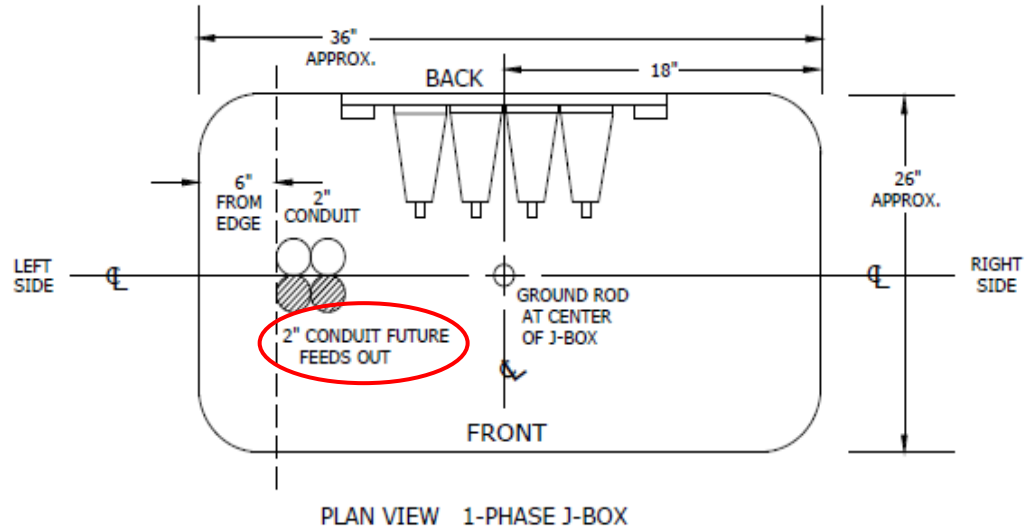

Rev 4: Changed to Voltage-reset fault indicators and added equipment lock.



CONSTRUCTION STANDARDS PRIMARY JUNCTION BOX SINGLE PHASE

REVISIONS			
Δ	DATE	ENGR	OPS
1	2/23/00	HWH	MA
2	9/23/04	LB	AH
3	12/29/04	LB	AH
4	4/29/09	CM	AH

PAGE:
2 of 2

UJ1

CAD FILE:
UJ1

APP: JEH SECTION
DATE: 2/22/00 1500

Single Phase J-Box

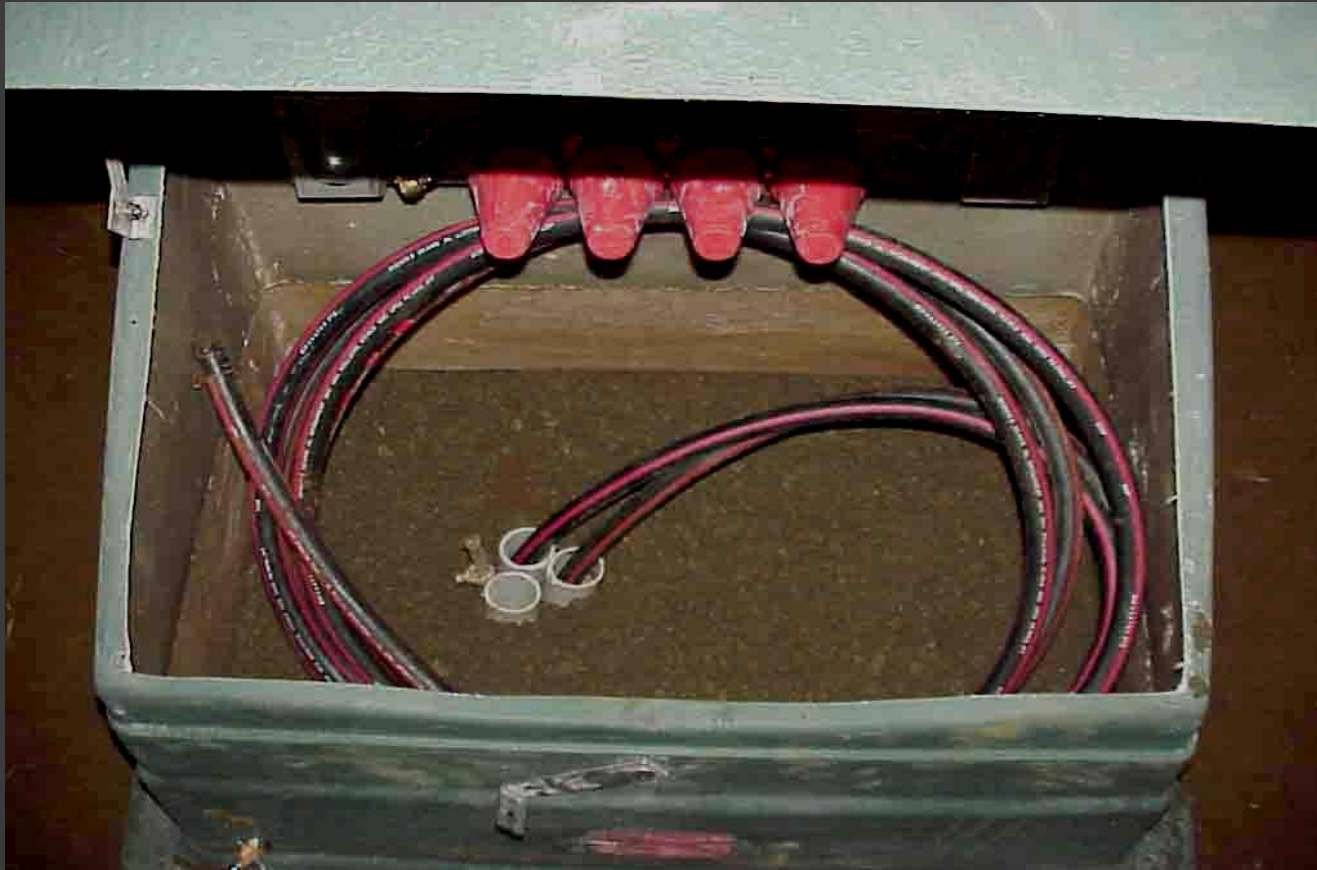

- Make sure to 5 star the lid closed before backfilling
- Backfill with gravel
- Pull in extra cable for make up

Single Phase J-Box

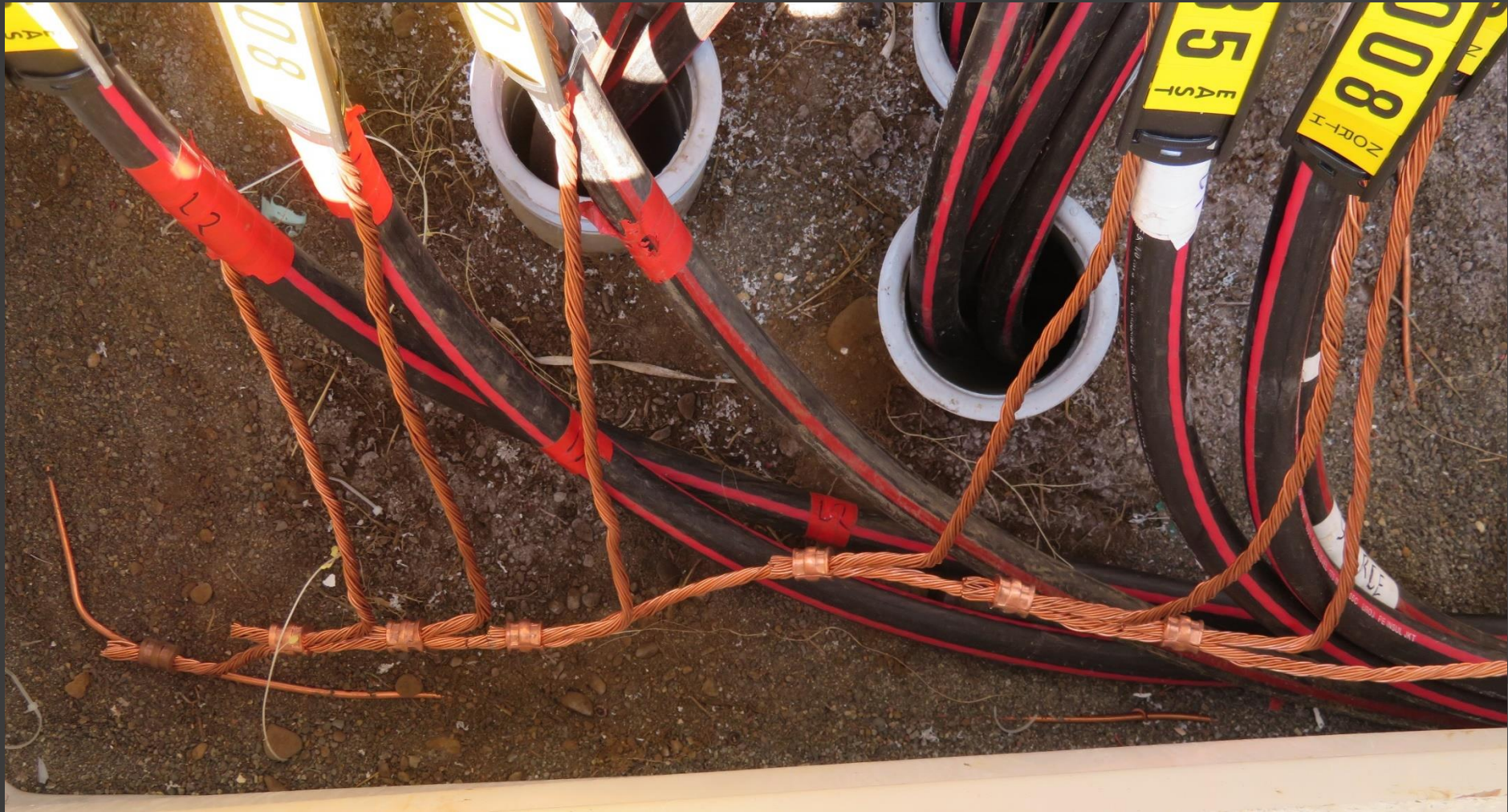

- Piggy back the concentrics
- Attach to the ground wire

Single Phase J-Box



- ⦿ Grade to the ground line
- ⦿ Install the number stickers

Three Phase J-Box

Three Phase J-Box

- Construction standard for a three phase J-box

NOTES:

- TYPICAL ELBOW ARRANGEMENT IS SHOWN.
- DO NOT PUT DIRT INSIDE JUNCTION BOX. SPACE IS REQUIRED FOR CABLE SLACK AND OPERATING CLEARANCE.
- LEAVE CABLE SLACK FOR FUTURE OPERATIONS.

LEGEND:

- FAULT INDICATOR NORMALLY OPEN (ON STAND OFF BRACKET)

Rev 3: Changed to Voltage-reset fault indicators and added equipment lock.

UJM4	UJM41	UJM42	UJM43	UJM44	UJM45	UJM46	UJM47	UJM48	UJM49

ITEM	MATERIAL LIST DESCRIPTION	QTY	S/N
1	Ground Rod 5/8" x 8'	1	1124
2	Clamp, Ground Rod, Small	1	281
3	Junction Box, 30	1	2047
4	Equipment Lock, UG	1	837

REVISIONS			
DATE	ENGR.	OPS	
0 2/23/00	HW1	MA	
1 9/23/04	LB	AH	
2 12/29/04	LB	AH	
3 4/29/09	CH	AH	

		CONSTRUCTION STANDARDS	
		PRIMARY JUNCTION BOX THREE PHASE	
PAGE:	UJ3	CAD FILE:	UJ3
1 of 2			

APP:	AH	SECTION:	1500
DATE:	2/22/00		

Three Phase J-Box

- Construction standard for a three phase J-box – vertical view

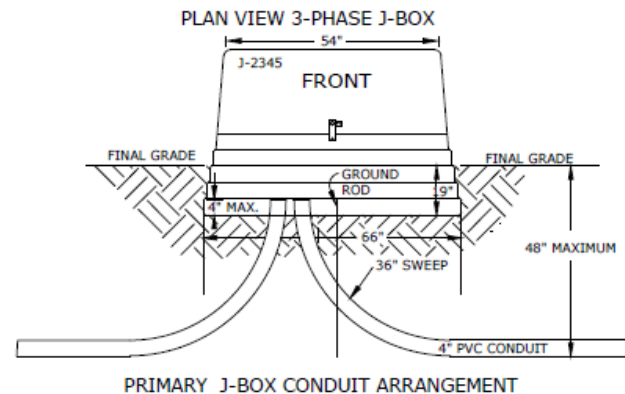
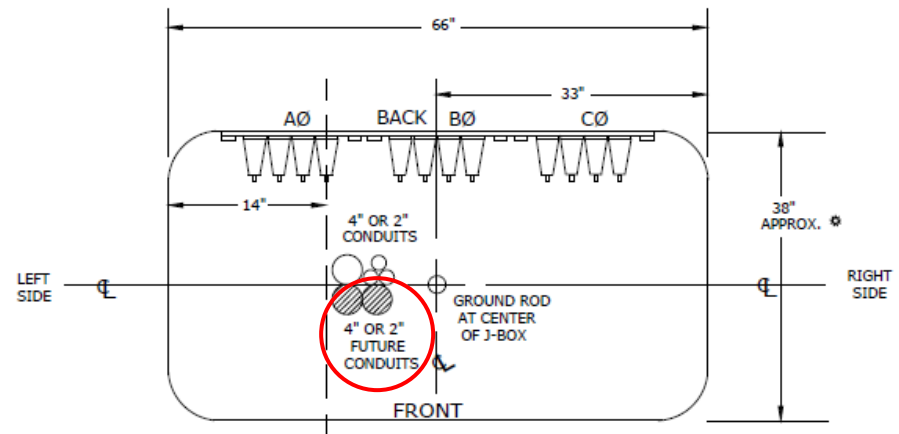

Rev 3: Changed to Voltage-reset fault indicators and added equipment lock.



CONSTRUCTION STANDARDS PRIMARY JUNCTION BOX THREE PHASE

REVISIONS			
DATE	ENGR	OPS	
2/23/00	HHH	MA	0
9/23/04	LB	AH	1
12/29/04	LB	AH	2
4/23/09	CM	AH	3

PAGE:
2 of 2

UJ3

CAD FILE:
UJ3

APP: AH SECTION
DATE: 2/22/00 1500

Three Phase J-Box



- Terminate, tape and hard tag the cable
- The source will be on the right
- The load will follow the source from right to left
- Phasing is ABC left to right

Three Phase J-Box

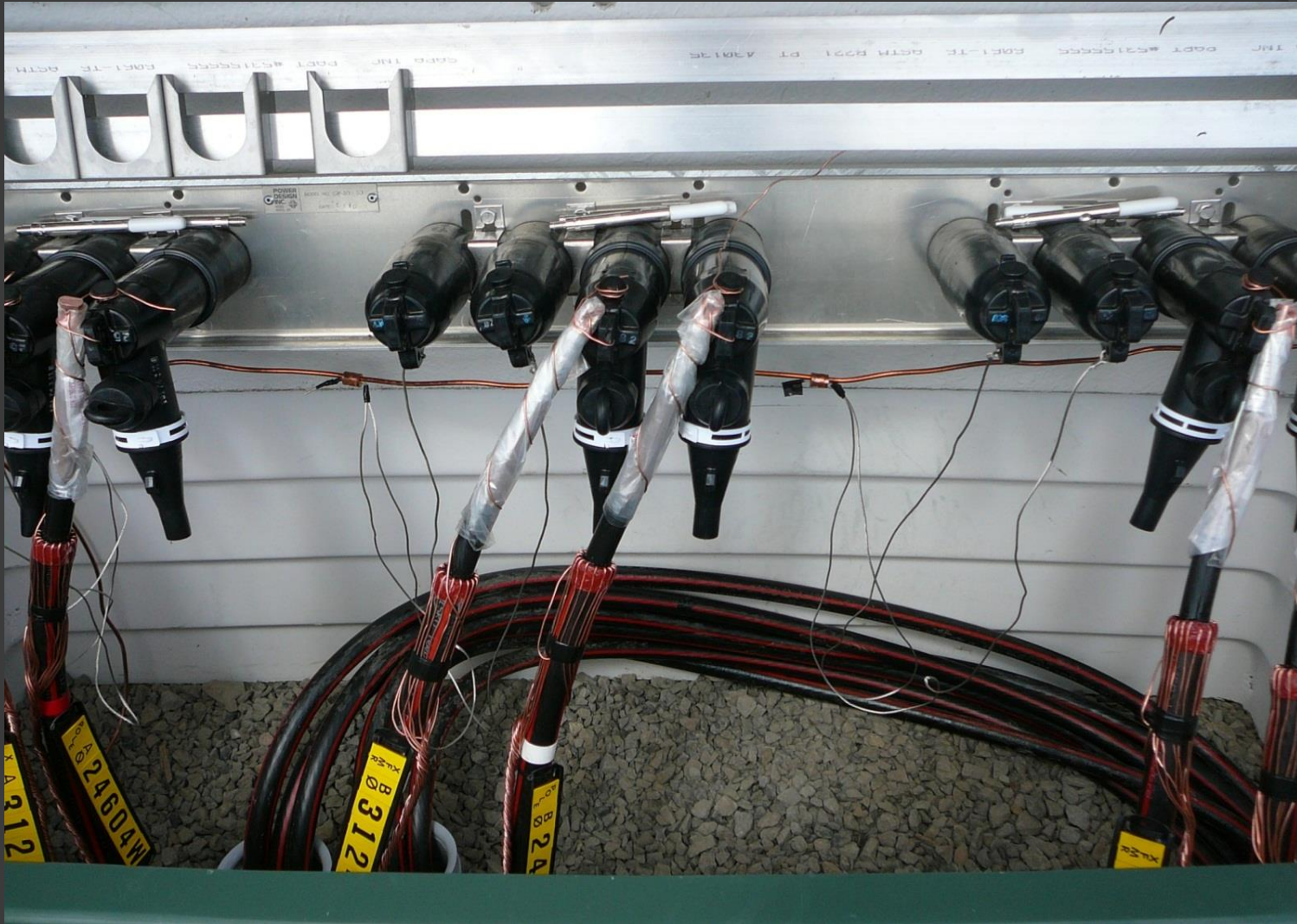

- ⦿ Attach the dust cover bleeder wires to the ground wire

Three Phase J-Box

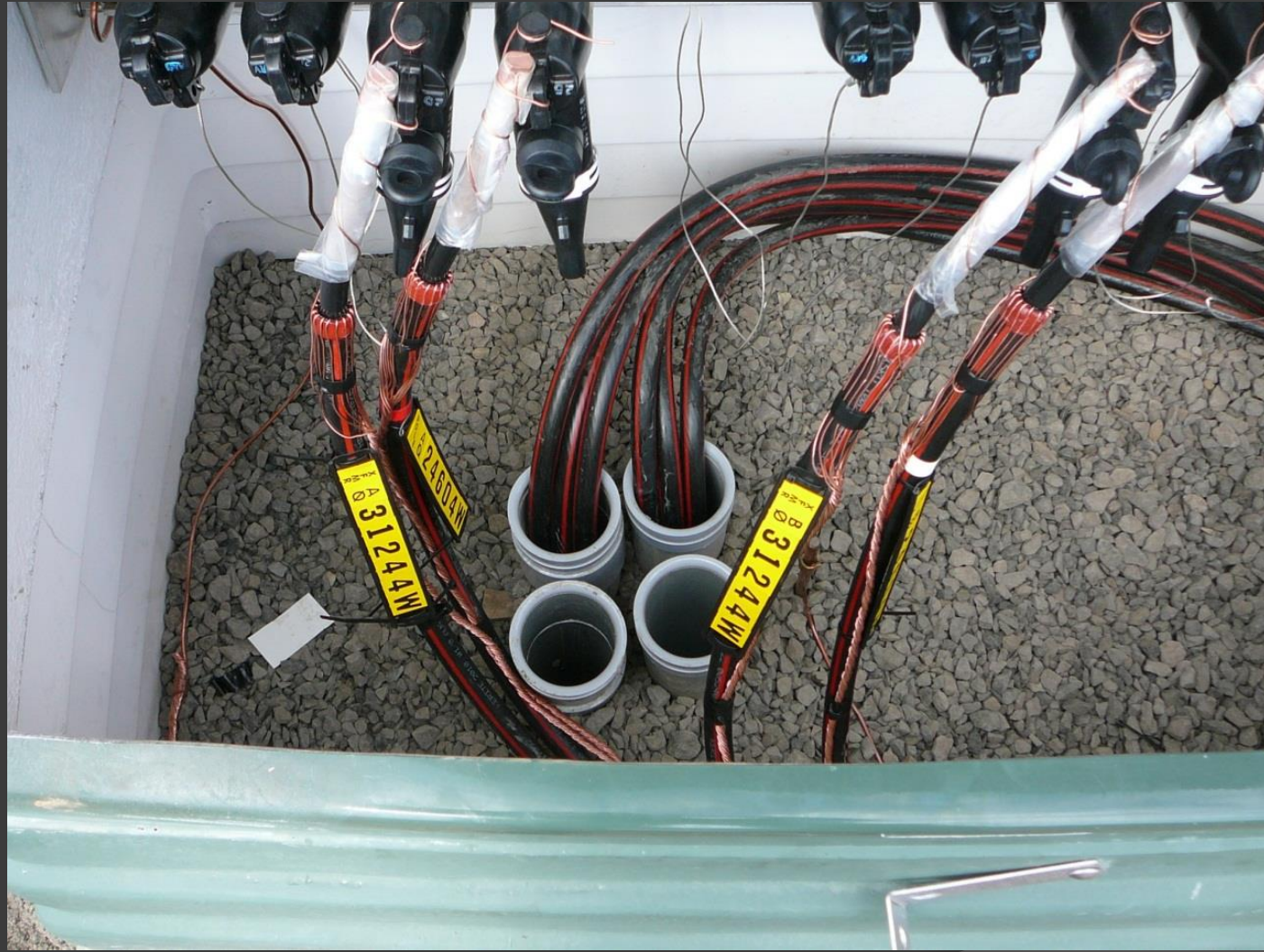

- Roll the wire out of the conduit

Three Phase J-Box



- Example of good make up

Three Phase J-Box

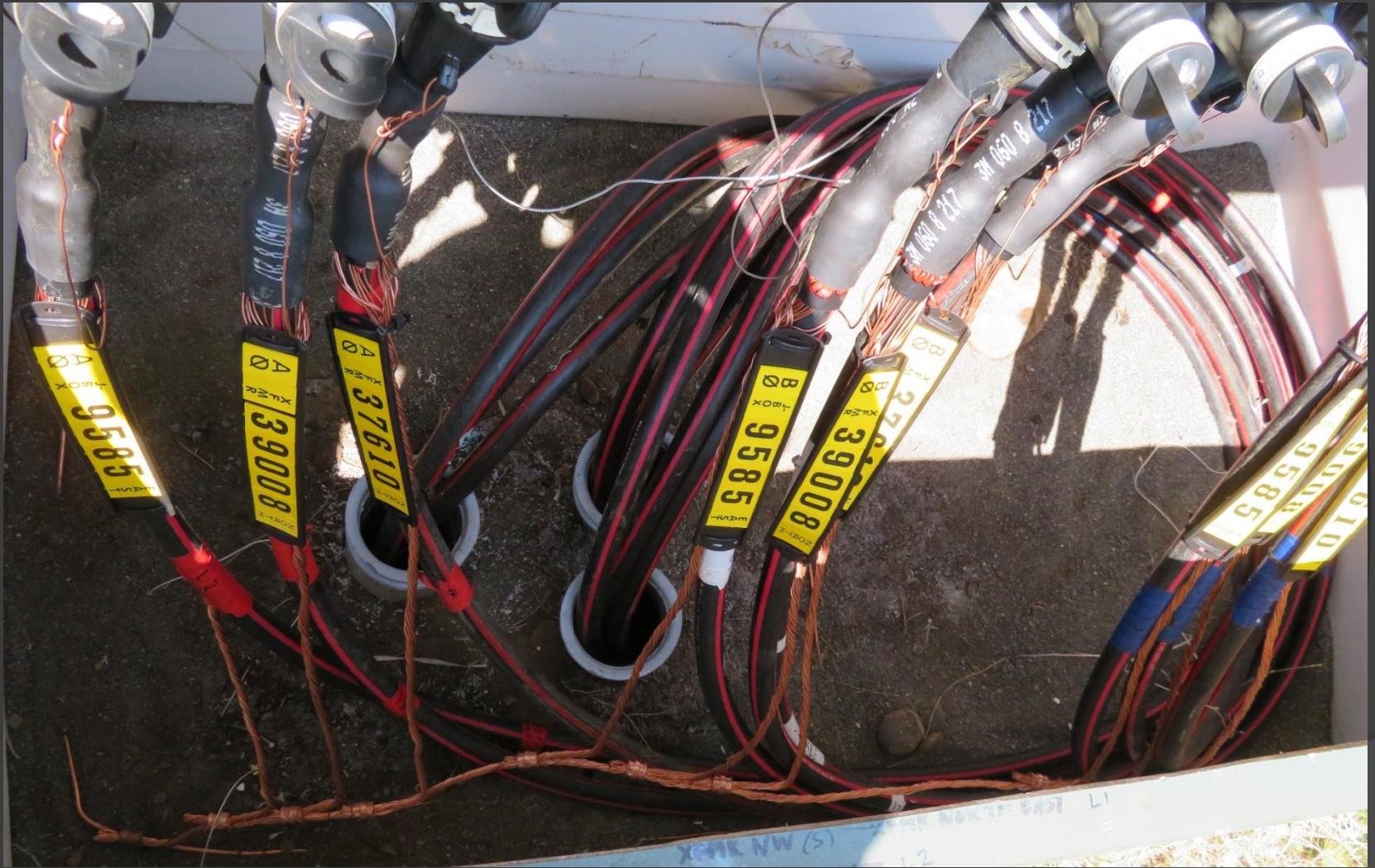

- Keep the neutrals in front of the wire and organized with slack

Three Phase J-Box

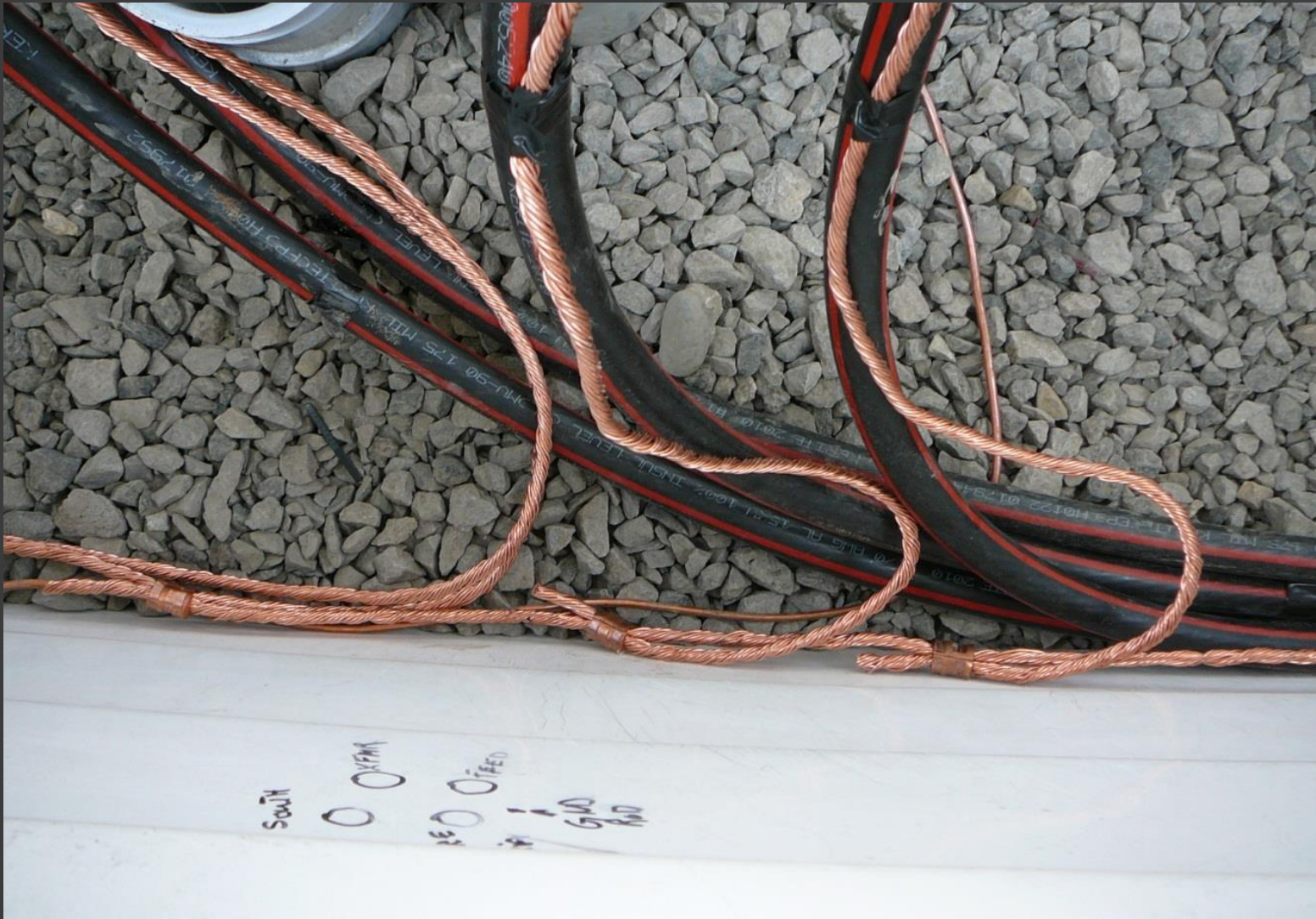

● Example of neutral slack

Three Phase J-Box



- ⦿ The neutral crosses behind trapping the primary, this is not acceptable

Three Phase J-Box



⦿ A good make up

Conduit Futures

Conduit Futures



- Use a marker pipe
- Plug the end in the ground
- Do NOT glue 90° elbow
- Place a 3M locate disk at the end of the pipe

Conduit Futures



- Place a Loop Enclosure (LE) over the pipe
- Make sure to bury the LE

Conduit Futures



- Hard tag both ends of the future
- The more information the better

Conduit Futures



- ⦿ This is a conduit plug
- ⦿ Attach pulling tape to the eye
- ⦿ Make sure to leave slack in the pulling tape

Plumbing Risers

Plumbing Risers



Plumbing Risers



⦿ Do not do this!

Plumbing Risers



- ⦿ Contractor is responsible for the cable – you are taking a chance leaving it like this

Plumbing Risers



Example of contractor protecting the wire at the bottom of the pole.

Closing

- ◎ Please, remember that Clark Public Utilities is customer owned
 - Treat our customers and employees with respect
 - We are here to help
 - Thank you for making this a successful program

APPROVED
PRIMARY ELECTRICAL
INSTALLATION



QUESTIONS

Contractor Training Class
2023