

**ABOVE GROUND
INSTALLATION ONLY**

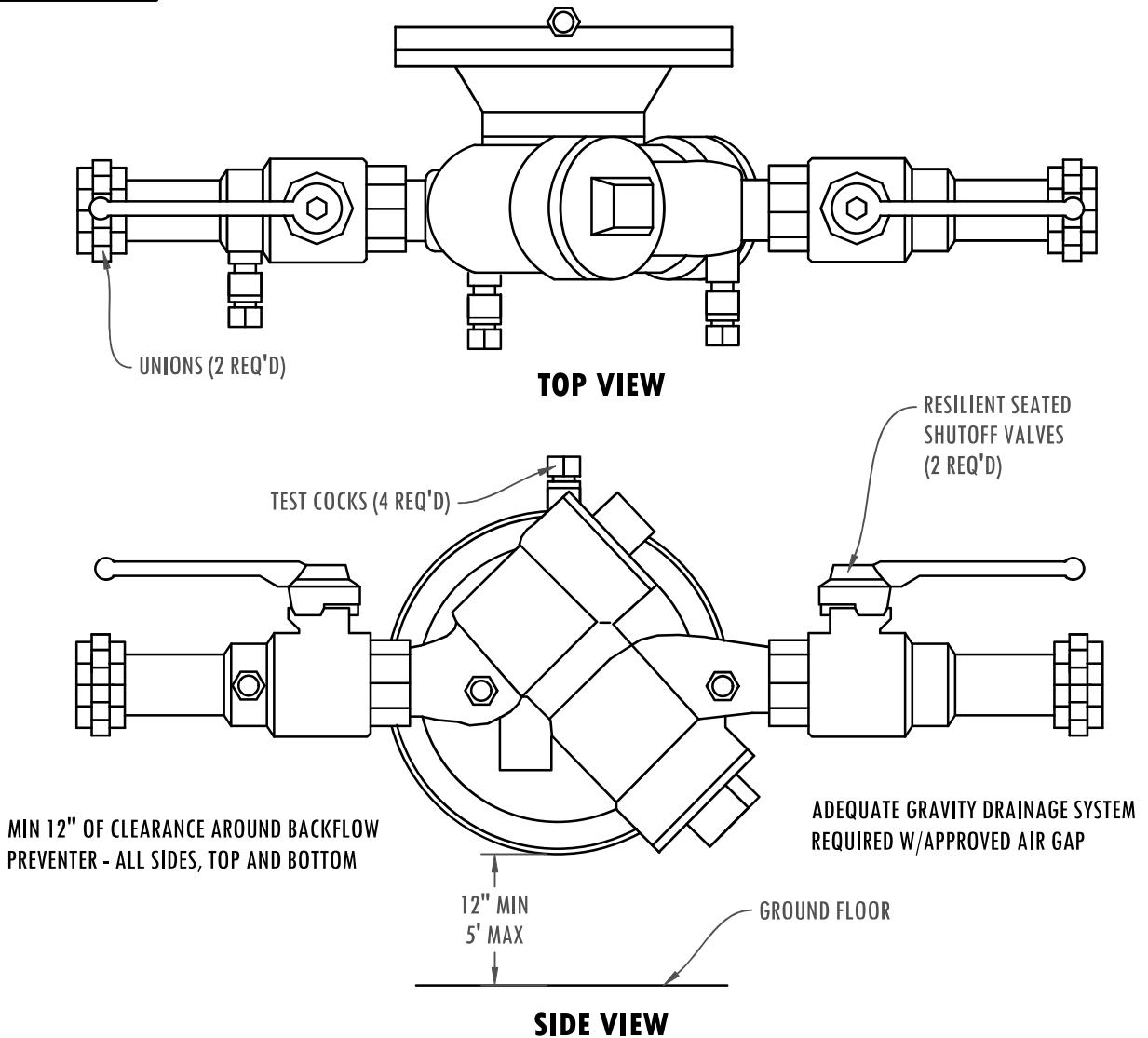

NOTES:

1. APPROVED REDUCED PRESSURE BACKFLOW ASSEMBLY TO BE INSTALLED ABOVE GROUND ONLY WITH MINIMUM CLEARANCES.
2. DESIGNED FOR BACK SIPHONAGE AND BACK PRESSURE.
3. TEST COCKS TO EITHER FACE OUTWARDS OR UPWARDS FROM ASSEMBLY.
4. DISINFECT, PRESSURE TEST AND THOROUGHLY FLUSH LINES PRIOR TO INSTALLATION OF BACKFLOW PREVENTER.
5. DO NOT INSTALL IN AN AREA SUBJECT TO FLOODING.
6. MUST BE PROTECTED FROM FREEZING CONDITIONS INSIDE AN INSULATED BOX COMMONLY REFERRED TO AS A HOT BOX.
7. THE BACKFLOW ASSEMBLY SHALL BE A STATE APPROVED MODEL.
8. A PLUMBING PERMIT IS REQUIRED. PLEASE CONTACT YOUR LOCAL PLUMBING PERMIT CENTER.
9. MUST BE TESTED AFTER INSTALLATION AND YEARLY THEREAFTER BY A WASHINGTON STATE CERTIFIED BACKFLOW ASSEMBLY TESTER. TEST RESULTS SHALL BE SENT TO CLARK PUBLIC UTILITIES WATER SERVICES.

REVISED JANUARY 2025

FILE NAME		STANDARD RPBA (REDUCED PRESSURE BACKFLOW ASSEMBLY) 2" & SMALLER	
21W			
SHEET	1 OF 1	STANDARD DETAILS	